



CVC TECHNOLOGIES, INC.



www.cvctechnologies.com

U.S. Headquarters: Fontana, California



● CVC Technologies, Inc.
10861 Business Drive, Fontana, CA 92337, USA
Phone: +1 (909) 355-0311
Fax: +1 (909) 355-0411
<http://www.cvcusa.com>
E-mail: sales@cvcusa.com

● CVC USA East Coast Office
1855 New Highway, Suite C, Farmingdale NY 11735
Phone: +1 (909) 355-0311
Fax: +1 (909) 355-0411
E-mail: sales@cvcusa.com

Asia Headquarters: Taiwan Manufacturing Center



● CVC Technologies, Inc. (Taiwan)
Asia Pacific Headquarters
No.190, Gongye 9th Rd., Dali Dist., Taichung City 412, Taiwan
Phone: +886 (4) 2496-3666
Fax: +886 (4) 3705-6555
E-mail: sales@cvctechnologies.com

● CVC Technologies, Inc. (India)
601/602, Manmandir Suraksha, Building No.3, Nahur Village Road,
Mulund (W), Mumbai - 400 080
Phone: +91 (22) 2562-1242, +91 (22) 2562-1243
Fax: +91 (22) 2562-1244
E-mail: sales@cvctechnologies.com

● CVC Technologies, Inc. (China)
No.77, Kangzhuang Road, Kunshan, China
Postal Code: 215314
Phone: +86 (512) 8363-6368
Fax: +86 (512) 8363-6638
E-mail: sales@cvctechnologies.com



focusing on
WHAT MATTERS THE MOST
to our customers



CVC TABLET & CAPSULE PACKAGING SYSTEMS

INNOVATIVE SIMPLE SMART SOLUTIONS

FOR COMPLEX PACKAGING REQUIREMENTS

FOCUSING ON WHAT MATTERS

CVC Technologies is committed to one goal: Helping our customers find the best possible solution to their packaging needs. We focus on what matters most to our customers: Quality, Value, and Service. These are the parameters by which CVC defines its business philosophy. CVC integrated sold dose packaging lines are suitable for a wide variety of applications including:

- Generic
- OTC (Over the Counter)
- Beauty & Personal Cares
- Diagnostics
- Nutraceuticals
- Pharmaceuticals



We commit to all CVC customers to supply excellent equipment and technical service to maximize production efficiency, reduce operating costs, and ensure quality products.



QUALITY · VALUE · SERVICE

We continue to expand our capabilities, re-invest into our operations, and add additional talents to our team. Our extensive application experience can solve almost any packaging challenge.

▼ ELECTRONIC COUNTER PACKAGING LINE

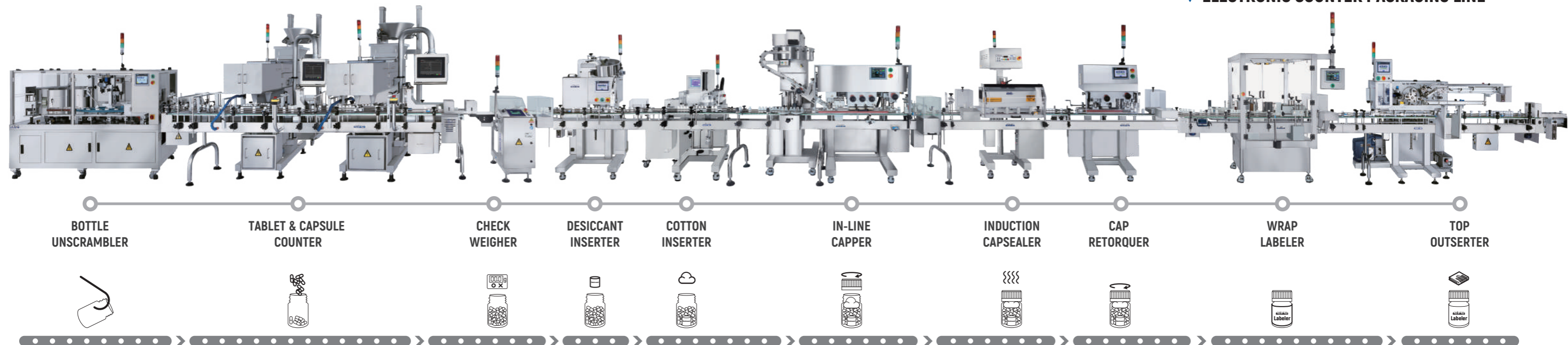

▼ CVC 1266



The CVC 1266 Bottle Unscrambler is designed to automatically feed bottles from a bin and place them upright onto a conveyor at speeds of up to 200-280 bottles per minute. The CVC 1266 is built on a Siemens control system including a HMI panel. Options include ionized air rinse with vacuum, fallen bottle sensor with return to bin, low level hopper sensor, tower lamp, and static eliminator bar. No change parts are required.

STANDARD FEATURES

- Display Touchscreen Instruction for Machine Operation is in English
- Memory Capacity for 50 Jobs
- Interlocked Safety Guarding
- Low Level Hopper Sensor
- Bottle Backlog Sensor at Outfeed
- Type 304 Stainless Steel Bin, Frame, Enclosure Panels
- Type 316 Stainless Steel Contact Parts
- ISO 9001:2015 Certified

AVAILABLE OPTIONS

- Static Eliminator Bar in Disc Sorter
- Ionized Air Rinsing Assembly with Vacuum
- Upside Down Bottle, Fallen Bottle Reject Assembly
- Tower Lamp
- 21 CFR Part 11 License
- OPC UA for data collection



STANDARD FEATURES

- Display touchscreen instruction for machine operation is in English
- Interlocked safety guarding
- Low level hopper sensor
- Bottle backlog sensor at outfeed
- Type 304 stainless steel bin, frame, enclosure panels
- Type 316 stainless steel contact parts
- ISO 9001:2015 certified



• Bottle orientating assembly



• Air Rinse Station

▼ CVC 1263



▼ CVC 1263D



	Technical Specifications		Technical Specifications	
Model	CVC 1266	CVC 1263	CVC 1263D	CVC 1263D
Type	U4	U4	U4	U4
Productivity	Up to 280 BPM (base on 100ml round bottle, subject to trial confirmation)	Up to 80 BPM (base on 100ml round bottle, subject to trial confirmation)	Up to 80 BPM (base on 100ml round bottle, subject to trial confirmation)	Up to 120 BPM (base on 100ml round bottle, subject to trial confirmation)
Applicable Size	Bottle Dia.: Ø30-120 mm (1 1/4" to 4 3/4") Bottle Height: 45-200 mm (1 3/4" to 7 3/4") Bottle Height/Dia Ratio: Min. 1.5:1	Bottle Dia.: Ø30-80 mm (1 1/4" to 3 1/8") Bottle Height: 50-150 mm (2" to 5 3/4") Bottle Height/Dia Ratio: Min. 1.5:1	Bottle Dia.: Ø30-80 mm (1 1/4" to 3 1/8") Bottle Height: 50-150 mm (2" to 5 3/4") Bottle Height/Dia Ratio: Min. 1.5:1	Bottle Dia.: Ø30-120 mm (1 1/4" to 4 3/4") Bottle Height: 50-200 mm (2" to 7 3/4") Bottle Height/Dia Ratio: Min. 1.5:1
Hopper Capacity	396 L (14 Cuft)	155 L (5.5 Cuft)	155 L (5.5 Cuft)	180 L (6.4 Cuft)
Air Filter Efficiency	0.01 µm (99.99 %) (for optional Ionized air rinsing assembly)	0.01 µm (99.99 %)	0.01 µm (99.99 %)	0.01 µm (99.99 %)
Power Source	220 V, 50/60 HZ, 1 PH	220 V, 50/60 HZ, 1 PH	220 V, 50/60 HZ, 1 PH	220 V, 50/60 HZ, 1 PH
Power Consumption	1,900 VA (8.7A) (when equipped with Air Rinse & Vacuum)	1,700 VA (7.8 A) (when equipped with Air Rinse & Vacuum)	1,700 VA (7.8 A) (when equipped with Air Rinse & Vacuum)	1,900 VA (8.7 A) (when equipped with Air Rinse & Vacuum)
Air Pressure	6 bar (87 psi)	6 bar (87 psi)	6 bar (87 psi)	6 bar (87 psi)
Air Consumption	1,300 NL/min (46 CFM) (when equipped with Air Rinse Assembly)	1,300 NL/min (46 CFM) (when equipped with Air Rinse Assembly)	1,300 NL/min (46 CFM) (when equipped with Air Rinse Assembly)	1,500 NL/min (53 CFM) (when equipped with Air Rinse Assembly)
Machine Dimensions (L x W x H)	2,200 x 1,235 x 1,980 mm (approx) (7'-3" x 4'-1" x 6'-6")	1,635 x 1,475 x 1,970 mm (approx) (5'-4" x 4'-10" x 6'-6")	1,635 x 1,475 x 1,970 mm (approx) (5'-4" x 4'-10" x 6'-6")	2,380 x 1,935 x 2,140 mm (approx) (7'-10" x 6'-4" x 7')
Machine Weight	707 kg (1,559 lbs)	700 kg (1,543 lbs)	700 kg (1,543 lbs)	1,200 kg (2,646 lbs)
Noise Level	≤ 78 dB	≤ 78 dB	≤ 78 dB	≤ 78 dB

* Machine specifications are subject to change without notice.

* Machine specifications are subject to change without notice.

▼ CVC 1220C



▼ CVC 1220CS

(SERVO-DRIVEN FLAPS)

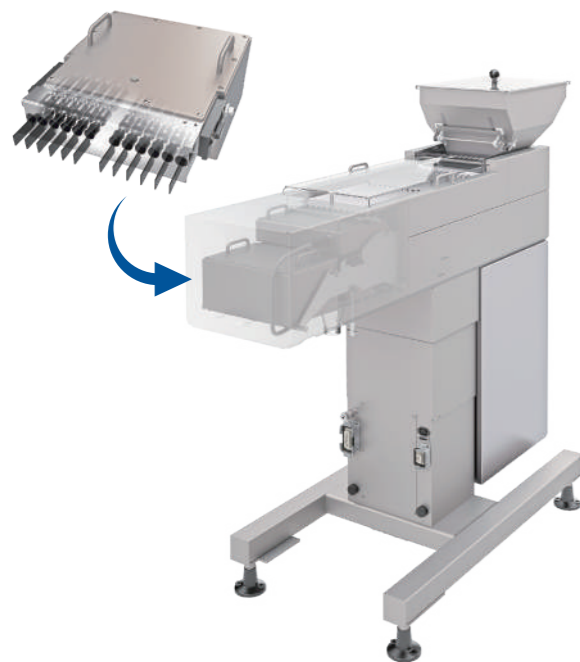

The CVC 1220C is an Electronic Channel Counter designed for high speed, highly accurate counting of tablets, capsules, and softgels. The machine comes standard with an automatic dust compensation system, dual vacuum ports, product count verification, and reject. The 1220C can be setup to run one bottle using all 12 channels. Options include hopper level control with tower Lamp, upside down bottle sensor, static eliminator bar, channel blocker, and floor loaded tablet pre-feeder.

The CVC 1220CS is our newest Electronic Channel Counter designed for high speed, highly accurate counting of tablets, capsules, and soft gels. The system has been upgraded with servo-driven flaps to improve accuracy of pre-count functions. In addition, the servo system adds to longevity of the assembly and reduce the requirement to replace pneumatically driven actuators.

STANDARD FEATURES

- 12 V-Shaped Channels Per Head (Tool Less Change Over)
- Auto dust compensation sensing system
- Dual dust extraction ports
- Powered Height Adjustment and Track Full/ Empty Sensors
- 2.83M-Motorized Single Lane Sanitary Conveyor (Single Head)
- 4.95M-Motorized Dual Lane Sanitary Conveyor (Dual Head)
- Rejection System
- Memory Capacity for up to 1000 Jobs (*Requires Touch Screen Controller)
- Stainless Steel Construction

AVAILABLE OPTIONS

- Channel Blocker
- Container Upside Down or Fallen Sensor
- Floor Loaded Pre-feeder with Integrated Controls
- Hopper Level Control System with Tower Lamp
- Industrial PC, Windows 10 (21 CFR Part 11 Compliant)
- Static Eliminator Bar
- Dual Counting Heads are Available
- Customized Vibratory Plates
- Vision Inspection (OEM)

CVC 1220C/ 1220CS Technical Specifications

Productivity	Up to 50-55 BPM (subject to trial confirmation)
Applicable Size	Bottle Dia.: Ø30-110 mm (1 1/4" to 4 1/4") Bottle Height: 50-200 mm (2" to 7 3/4")
Hopper Capacity	35 L (1.24 Cuft)
Power Source	230 V, 50/60 HZ, 1 PH
Power Consumption	1220C: 725 VA (3.2 A) 1220CS: 950 VA (4.2 A)
Air Pressure	5 bar (73 psi)
Air Consumption	1220C: 200 NL/min (7.1 CFM) 1220CS: 50 NL/min (1.8 CFM)
Machine Dimensions [L x W x H]	680 x 1,780 x 1,870 mm (approx) [2'-3" x 5'-10" x 6'-2"]
Machine Weight	1220C: 425 kg (937 lbs) 1220CS: 475 kg (1,047 lbs)
Noise Level	75-80 dB

* Machine specifications are subject to change without notice.



- To avoid product spillage, filling nozzle dips to cover the neck once bottle is positioned for filling.
- Motorised height adjustment makes job easier.



- Standard hand-held terminal features quick setup and ease of operation.



- Touch Screen Terminal (TST), 12.1" Panel Computer, Win10 IoT ENT provides the following features:
 - production data print out
 - Production History
 - Current machine settings from the machine settings menu.
 - Revolving type mounting bracket for TST
 - Electronic records and electronic
 - Electronic records and electronic signatures are features, in compliance with the regulations of the FDA, as described 21 CFR Part 11



- 12 linear channels with 3 stages of vibration units separate and transmit tablets/capsules to the detection unit. Each individual channel is equipped with multiple sensors to count products in free fall and with a special "dust" compensator to assure counting accuracy.

▼ UNIQUE "QUICK DISASSEMBLY" DESIGN FOR QUICK AND EASY CLEAN-UP

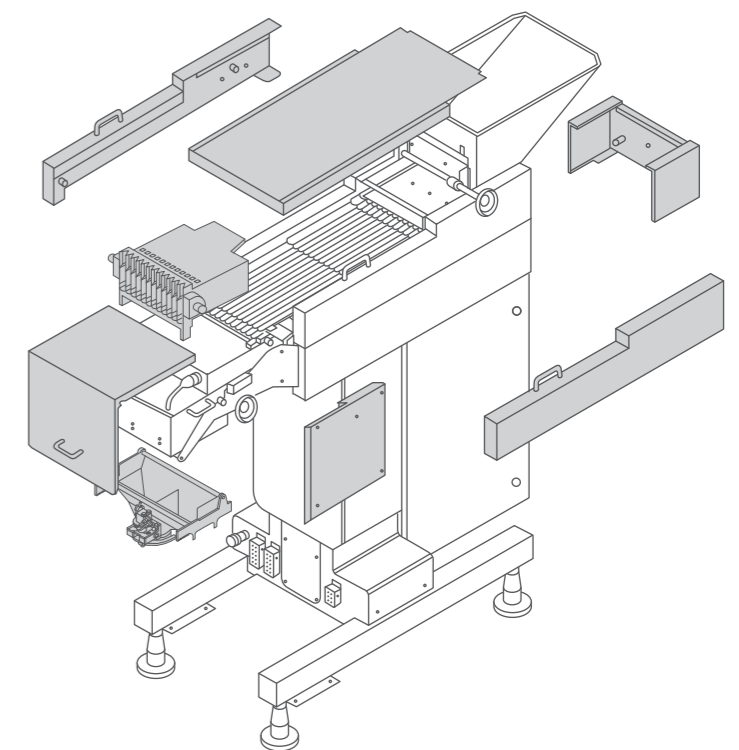

- To prevent cross-contamination, cGMP requires that all product contact parts be cleaned up when products change.

▼ CVC 1620C



The CVC 1620CS Electronic Channel Counter is designed for high speed, highly accurate counting of tablets, capsules, and softgels. The machine comes standard with an automatic dust compensation system, dual vacuum ports, product count verification, and reject. The 1620CS can be setup to run one bottle using all 16 channels or two bottles using 8 channels for each bottle. Options include touch screen industrial PC, hopper level control with tower Lamp, upside down bottle sensor, static eliminator bar, channel blocker, and floor loaded pre-feeder.

STANDARD FEATURES

- 16 V-Shaped Channels per head, tool less change over
- Auto dust compensation sensing system
- Dual Dust Extraction Ports
- Powered Height Adjustment and Track Full/ Empty Sensors
- 2.83M-Motorized Sanitary Conveyor
- Single or Double Bottle Discharge
- Rejection System
- Memory Capacity for up to 1000 Jobs (*Requires Touch Screen Controller)
- Stainless Steel Construction

AVAILABLE OPTIONS

- Channel Blocker
- Container Upside Down or Fallen Sensor
- Floor Loaded Pre-feeder with Integrated Controls
- Hopper Level Control System with Tower Lamp
- Industrial PC, Windows 10 (21 CFR Part 11 Compliant)
- Static Eliminator Bar
- Dual Counting Heads are Available
- Customized Vibratory Plates
- Vision Inspection (OEM)

CVC 1620CS Technical Specifications

Productivity	Up to 75-80 BPM (used with double discharge funnel) (subject to trial confirmation)
Applicable Size	Bottle Dia.: Ø30-110 mm (1 1/4" to 4 1/4") Bottle Height: 50-200 mm (2" to 7 3/4")
Hopper Capacity	36 L (1.27 Cuft)
Power Source	230 V, 50/60 HZ, 1 PH
Power Consumption	1,100 VA (4.8 A)
Air Pressure	5 bar (73 psi)
Air Consumption	100 NL/min (3.5 CFM)
Machine Dimensions [L x W x H]	680 x 1,970 x 1,851 mm (approx) [2'-3" x 6'-6" x 6'-1"]
Machine Weight	500 kg (1,102 lbs)
Noise Level	75-80 dB

* Machine specifications are subject to change without notice.

OPTION:
The Touch Screen

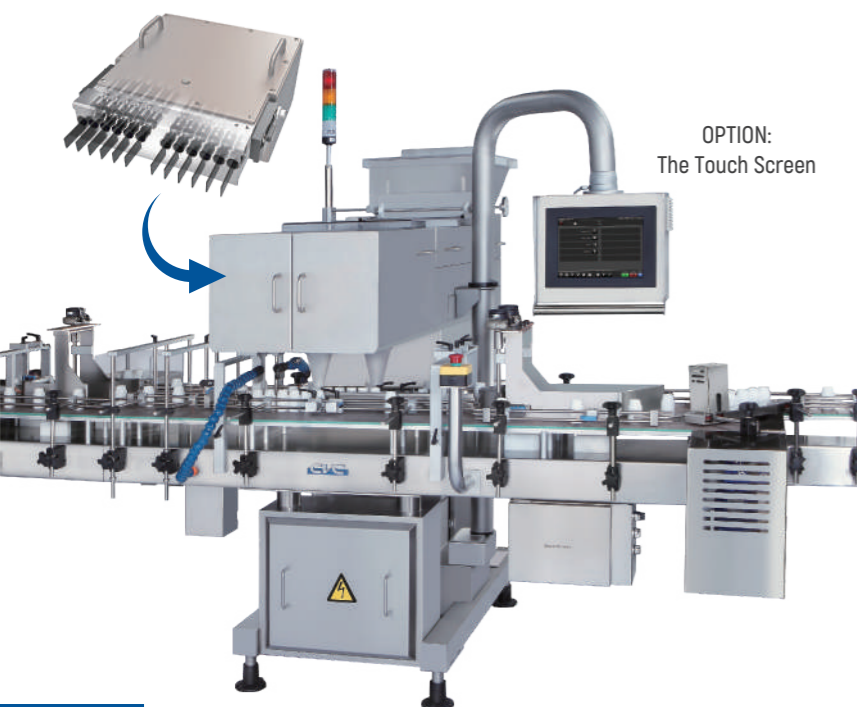

▼ UNIQUE "QUICK DISASSEMBLY" DESIGN FOR QUICK AND EASY CLEAN-UP

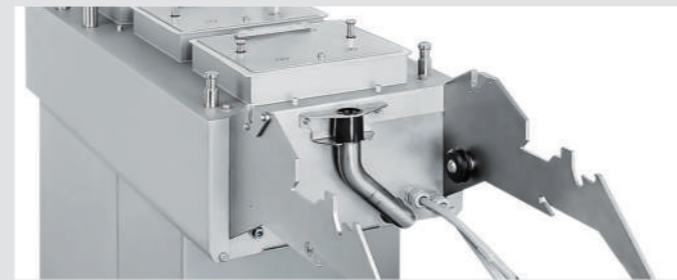

• The unique interlocking of the counting head components provides the ultimate cleaning ease as the operator simply turns off the air supply to remove the "air locked" vibratory plates.



• When parameters are set incorrectly, optional auto rejection system removes irregular containers from the conveyor to secure counting accuracy.
• The message of rejection will be shown on the control panel and the amount of rejected bottle will be deducted from the total counts.

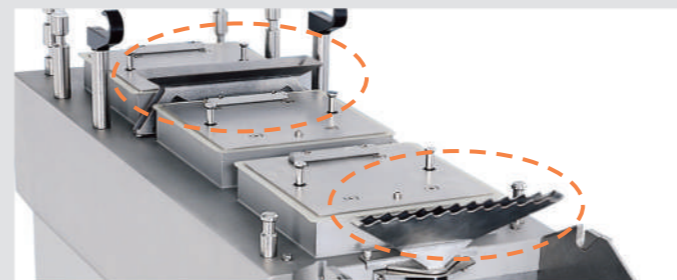

• Newly advanced dust vacuum port gives more powerful and efficient vacuuming capability.
• Product "dust" is drawn out via 2 extraction tubes to the collector located underneath the hopper and the front vibratory plates.
• Tool-less release, quick & easy cleaning.



• 16 linear channels with 3 stages of vibration units separate and transmit tablets/capsules to the detection unit. Each individual channel is equipped with multiple sensors to count products in free fall and with a special "dust" compensator to assure counting accuracy.

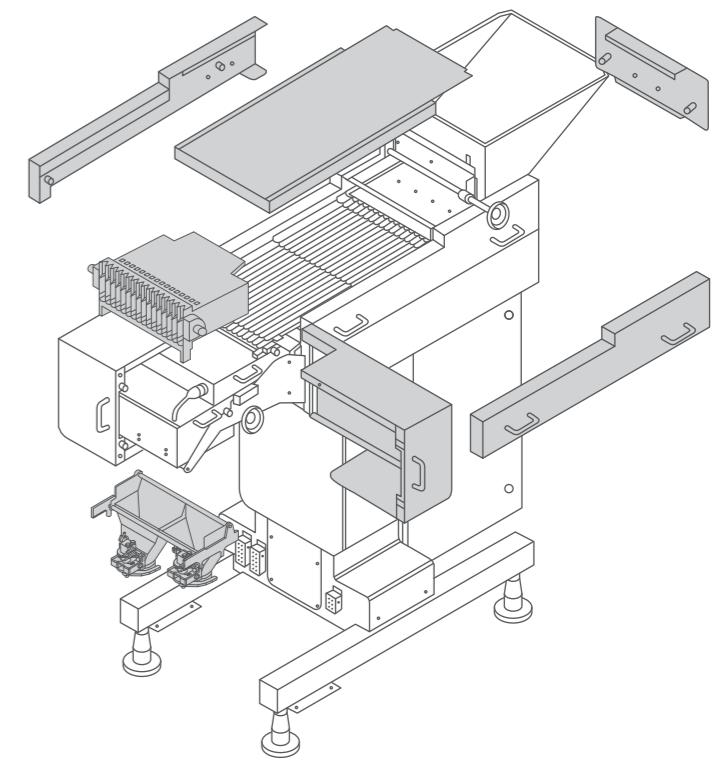

• To prevent cross-contamination, cGMP requires that all product contact parts be cleaned up when products change.

▼ CVC 1101C



▼ CVC 1101E



The CVC 1101C and the CVC 1101E pre-feeding systems are pharmaceutical grade low profile tablet pre-feeders, designed with a streamline easy-to-clean hopper, that would accommodate both tablets and capsules. The system is a compactly designed with hopper bin lifting system to automatically elevate and deliver tablets or capsules from floor level to the hopper of the counter. The CVC 1101C is primarily used with single counting head while the CVC 1101E is used on dual-head counting system configurations.

STANDARD FEATURES

- On/Off is Automatically Triggered
- Timer for Tablet/ Capsule Feeding Time Control
- Height Adjustment is Made with a Handwheel (Hopper is Hooked when Power Cuts)
- All Contact Parts are made of SS 316L
- Full cGMP Compliance



Technical Specifications		
Model	CVC 1101C	CVC 1101E
Type	U1	U1
Productivity	Up to 20,000 PPM (subject to trial confirmation)	Up to 20,000 PPM (subject to trial confirmation)
Applicable Size	Product Dia.: Ø3-20 mm (1/8" to 3/4") Product Length: 3-30mm (1/8" to 1 1/4") Product Width: 3-20mm (1/8" to 3/4")	
Hopper Capacity	105 L (3.7 Cuft)	50 L (1.8 Cuft)
Power Source	220 V, 50/60 HZ, 1 PH	220 V, 50/60 HZ, 1 PH
Power Consumption	800 VA (3.7 A)	860 VA (4 A)
Air Pressure	N/A	6 bar (87 psi)
Air Consumption	N/A	5 NL/min (0.2 CFM)
Machine Dimensions (L x W x H)	915 x 1,210 x 2,745 mm (3' x 4' x 9')	690 x 1,740 x 2,625 mm (2'-3" x 5'-9" x 8'-7")
Machine Weight	294 kg (648 lbs)	350 kg (772 lbs)
Noise Level	≤ 78 dB	≤ 78 dB

* Machine specifications are subject to change without notice.

The CVC 1117 Series of Cotton Inserter is designed to insert polyester, rayon, or cotton coil into containers at speeds up to up to 120 bottles per minute. The CVC 1117 is Siemens PLC driven and Servo Motor controlled. Options include tower lamp, missing cotton in bottle detection, reject and reject verification. The cotton piece length can be set from 70mm to 150mm (2 3/4" to 5 3/4"). It can place from 1-10 inserts per bottles.

The CVC 1117 Series can be fitted over existing conveyor while the CVC 1117D, with the extended cotton head, is designed to be integrated to a dual lane conveyor.

- Built to cGMP Standards
- Stainless Steel Construction
- Quick and Easy Change Over

CVC 1117 Technical Specifications

Type	U4
Productivity	Up to 100 BPM (subject to trial confirmation)
Applicable Size	Bottle Dia.: Ø30-110 mm (1 1/4" to 4 1/4") Bottle Height: 50-200 mm (2" to 7 3/4") Bottle Mouth Opening: Ø25-50 mm (1" to 2") Cotton Length: 70-150 mm (2 3/4" to 5 3/4")
Power Source	220 V, 50/60 HZ, 1 PH
Power Consumption	465 VA (2.2 A)
Air Pressure	6 bar (87 psi)
Air Consumption	350 NL/min (12.3 CFM)
Machine Dimensions (L x W x H)	715 x 1,000 x 1,890 mm (approx) (2'-4" x 3'-3" x 6'-2")
Machine Weight	165 kg (364 lbs)
Noise Level	≤ 80 dB

* Machine specifications are subject to change without notice.

The CVC1118F PE Film Inserter converts film into preset lengths which are later pushed into the bottles. The film is cut into desired lengths by feeding through a pair of pinch rollers and a cutter. Each piece is then folded and inserted up into a tube, forming the "inverted U", the tube then moves over the bottle and the film piece is inserted down into the bottle by means of air cylinder.

Machine capacity is up to 100 cycles per min.

All parts in contact with film meet cGMP requirements.

CVC 1118F Technical Specifications

Type	U4
Productivity	Up to 120 BPM (subject to trial confirmation)
Applicable Size	Bottle Dia.: Ø30-110 mm (1 1/4" to 4 1/4") Bottle Height: 50-200 mm (2" to 7 3/4") Bottle Mouth Opening: Ø25-50 mm (1" to 2")
Film Size	Film Tube Length: 119 mm (4 3/4") Film Roll Dimension: Core Dia.: 76 mm (3") Max. Roll Dia.: 260 mm (10 1/4") Cutting Film Length: 90-150 mm (3 1/2" to 5 3/4") Max. Film Thickness: 0.04 mm Max. Film Width: 180-240 mm (7" to 9 1/2")
Power Source	220 V, 50 HZ, 1 PH
Power Consumption	700 VA (3.2 A)
Air Pressure	6 bar (85 psi)
Air Consumption	350 NL/min (12.3 CFM)
Machine Dimensions (L x W x H)	528 x 968 x 2,160 mm (approx) (1'-9" x 3'-2" x 7'-1")
Machine Weight	308 kg (679 lbs)
Noise Level	≤ 78 dB

* Machine specifications are subject to change without notice.

▼ CVC 1117



▼ CVC 1118F



▼ CVC 1103



▼ CVC 1103H

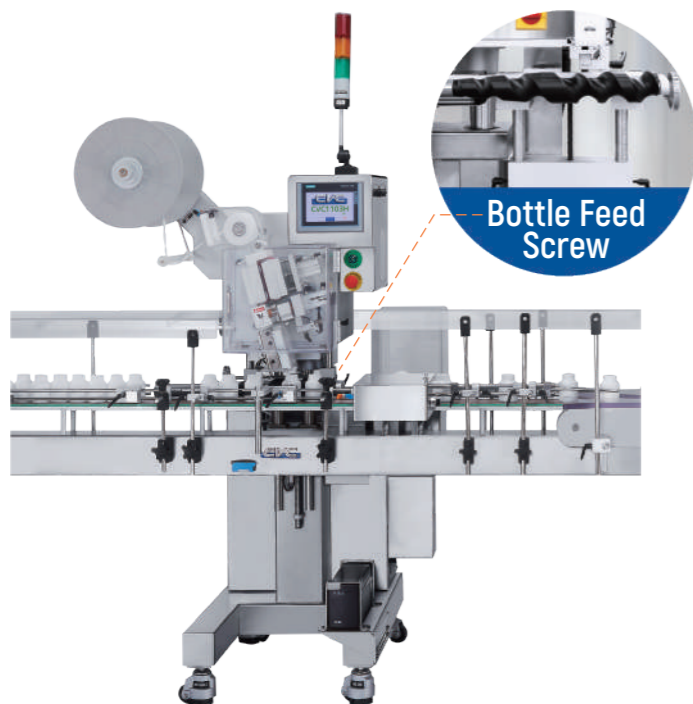

The CVC 1103 series of Desiccant Pouch Inserter is a compact highly cost-effective means to insert desiccants or oxygen absorbents into a variety of bottles and containers. The system cuts packets from a roll and inserts them into containers at speeds of up to 120/200 bottles per minute. The CVC 1103 is Siemens PLC controlled with servo motor. Options include tower lamp and feed screw for higher speed applications.

STANDARD FEATURES

- Servo Motor & Siemens PLC Controlled
- Safety Guards with Automatic Machine Stop
- Pneumatic Gating for Positive Stop
- Bottle Backlog Sensor
- 1 to 5 Pouch Insertions Per Bottle

AVAILABLE OPTIONS

- Infeed Feed Screw System for High Speed Applications
- Reject Station and Reject Verification Check
- Tower Lamp
- 21 CFR Part 11 License

CVC 1103 Technical Specifications	
Type	U4
Productivity	Up to 120 BPM (subject to trial confirmation)
Applicable Size	Pouch: Length: 33-73mm (1 1/4" to 2 7/8") Width: 17-30mm (5/8" to 1 1/4") Thickness: 3-10mm (1/8" to 3/8") Bottle: Dia.: Ø30-110 mm (1 1/4" to 4 1/4") Height: 50-200 mm (2" to 7 3/4")
Power Source	220 V, 50/60 HZ, 1 PH
Power Consumption	352 VA (1.6 A)
Air Pressure	6 bar (87 psi)
Air Consumption	96 NL/min (3.4 CFM)
Machine Dimensions (L x W x H)	862 x 886 x 1,964 mm (approx) (2'-10" x 2'-11" x 6'-5")
Machine Weight	143 kg (315 lbs)
Noise Level	≤ 70 dB

* Machine specifications are subject to change without notice.

CVC 1103H Technical Specifications	
Type	U4
Productivity	Up to 200 BPM (subject to trial confirmation)
Applicable Size	Pouch: Length: 33-75mm (1 1/4" to 2 7/8") Width: 17-30mm (5/8" to 1 1/4") Thickness: 3-10mm (1/8" to 3/8") Bottle: Dia.: Ø30-110 mm (1 1/4" to 4 1/4") Height: 50-200 mm (2" to 7 3/4")
Power Source	220 V, 50/60 HZ, 1 PH
Power Consumption	900 VA (4.1 A)
Air Pressure	6 bar (87 psi)
Air Consumption	115 NL/min (4 CFM)
Machine Dimensions (L x W x H)	906 x 982 x 2,270 mm (approx) (3' x 3'-3" x 7'-5")
Machine Weight	190 kg (419 lbs)
Noise Level	≤ 70 dB

* Machine specifications are subject to change without notice.

The CVC 1112 Desiccant Canister Inserter sorts and dispenses desiccant barrels into containers at speeds of up to 150/200 bottles per minute. The system is designed to comply with cGMP requirements and is controlled by Siemens PLC and servo motor.

STANDARD FEATURES

- Servo Motor & Siemens PLC Controlled
- No-bottle No-fill
- Safety Guards with Automatic Machine Stop
- Pneumatic Gating for Positive Stop
- cGMP Compliance

AVAILABLE OPTIONS

- Infeed Feed Screw System for High Speed Applications
- Bottle Feed Screw or Servo Driven Feed Screw Hardware
- Reject Station
- Reject Verification Check
- Tower Lamp
- 21 CFR Part 11 License

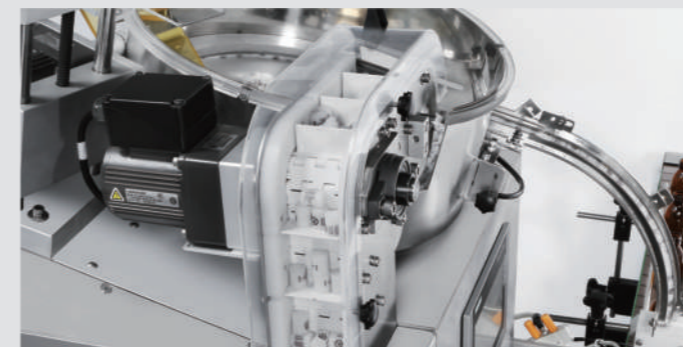

Technical Specifications		
Model	CVC 1112	CVC 1112H
Type	U4	U4
Productivity	Up to 150 BPM (subject to trial confirmation)	Up to 200 BPM (subject to trial confirmation)
Applicable Size	Product: Dia.: Ø14-20 mm (1/2" to 3/4") Height: 18-25mm (5/8" to 1") Bottle: Dia.: Ø30-110 mm (1 1/4" to 4 1/4") Height: 50-200 mm (2" to 7 3/4")	
Hopper Capacity	30 L (1 Cuft)	50 L (1.8 Cuft)
Power Source	220 V, 50/60 HZ, 1 PH	220 V, 50/60 HZ, 1 PH
Power Consumption	450 VA (2.1 A)	Pneumatic gating: 450 VA (2.1 A) Bottle feed screw: 1,002 VA (4.6 A)
Air Pressure	6 bar (87 psi)	6 bar (87 psi)
Air Consumption	361 NL/min (12.8 CFM)	Pneumatic gating: 361 NL/min (12.8 CFM) Bottle feed screw: 570 NL/min (20 CFM)
Machine Dimensions (L x W x H)	934x 966x 2,160 mm (3'-1" x 3'-2" x 7'-1")	1,150x 966x 2,160 mm (3'-9" x 3'-2" x 7'-1")
Machine Weight	210 kg (463 lbs)	220 kg (485 lbs)
Noise Level	≤ 83 dB	≤ 83 dB

* Machine specifications are subject to change without notice.

▼ CVC 1112



▼ CVC 1205

CVC 1200K
(CENTRIFUGAL CAP SORTER)



▼ CVC 1205

CVC 1200W
(CAP ELEVATOR SORTER)



The CVC 1205 Capper is a very flexible machine designed to apply and tighten screw-on caps onto containers at rates of up to 150 bottles per minute. The CVC 1205 is Siemens PLC controlled. Options include tower lamp, hopper level control, cap inspection (level cap, foil seal, and no cap), reject, and reject verification.

STANDARD FEATURES

- Siemens PLC Controlled
- Memory Capacity for 50 Jobs
- Cap Tightening Station with 3 Sets of Spindles
- 7.8 cu ft. Integrated Cap Hopper Elevator
- ISO 9001:2015 Certified

AVAILABLE OPTIONS

- Motorized Sanitary Conveyor (4 1/2" Wide Belt Standard or 6" Wide Belt Available)
- Tower Lamp, Hopper Level Control
- Cap Inspection Package (Level Cap, No Cap, Foil Presence)
- Rejection System, Reject Verification
- Press-on Cap Assembly, Dual-belt Gripping System
- 21 CFR Part 11 License

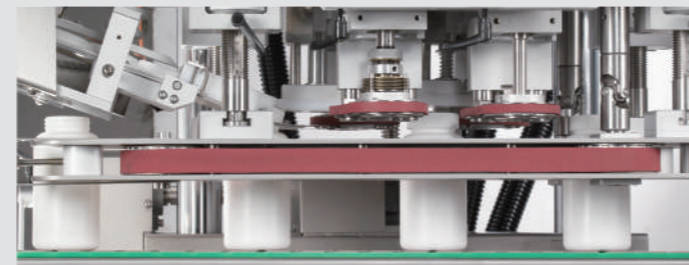

Mode	Technical Specifications		Technical Specifications	
	CVC 1205 + CVC 1200K	CVC 1205 + CVC 1200W	CVC 1206	CVC 1206H + CVC1200W
Type	U4	U4	U4	U4
Productivity	Up to 150 BPM (subject to trial confirmation)	Up to 150 BPM (subject to trial confirmation)	Up to 150 BPM (subject to trial confirmation)	Up to 200 BPM (subject to trial confirmation)
Applicable Size	Cap: Dia.: Ø30-110 mm (1 1/4" to 4 1/4") Height: 8-22 mm (5/16" to 7/8") Bottle: Dia.: Ø30-110 mm (1 1/4" to 4 1/4") with Cap Height: 50-220 mm (2" to 8 1/2")		Cap: Dia.: Ø30-90 mm (1 1/4" to 3 1/2") Height: 8-22 mm (5/16" to 7/8") Bottle: Dia.: Ø30-110 mm (1 1/4" to 4 1/4") with Cap Height: 50-220 mm (2" to 8 1/2")	
Hopper Capacity	110 L (3.9 Cuft)	220 L (7.8 Cuft)	210 L (7.4 Cuft)	220 L (7.8 Cuft)
Power Source	220 V, 50/60 HZ, 1 PH	220 V, 50/60 HZ, 1 PH	220 V, 50/60 HZ, 1 PH	220 V, 50/60 HZ, 1 PH
Power Consumption	1205: 1,320 VA (6 A) 1200K: 450 VA (2.1 A)	1205: 1,320 VA (6 A) 1200W: 220 VA (1 A)	1,540 VA (7 A)	1206H: 1,320 VA (6 A) 1200W: 220 VA (1 A)
Air Pressure	6 bar (87psi)	6 bar (87psi)	6 bar (87psi)	6 bar (87psi)
Air Consumption	1205: 200 NL/min (7 CFM) 1200K: 200 NL/min (7 CFM)	1205: 200 NL/min (7 CFM) 1200W: 200 NL/min (7 CFM)	200 NL/min (7 CFM)	1206H: 200 NL/min (7 CFM) 1200W: 200 NL/min (7 CFM)
Machine Dimensions (L x W x H)	1205: 1,595x 1,105x 2,265 mm 1200K: 780 x 1,420 x 2,290 mm (2'-7" x 4'-8" x 7'-6")	1205: 1,385 x 1,225 x 2,380 mm (4'-7" x 4' x 7'-10")	1,715 x 1,640 x 2,265 mm (5'-8" x 5'-5" x 7'-5")	1206H: 1,460 x 1,065 x 2,420 mm (4'-10" x 3'-6" x 7'-11") 1200W: 1,385x 1,225x 2,290 mm (4'-7" x 4' x 7'-6")
Machine Weight	1205: 457 kg (1,008 lbs) 1200K: 259 kg (571 lbs)	1205: 457 kg (1,007 lbs) 1200W: 435 kg (959 lbs)	764 kg (1,684 lbs)	1206H: 385 kg (849 lbs) 1200W: 435 kg (959 lbs)
Noise Level	≤ 60dB	≤ 60 dB	≤ 60 dB	≤ 60 dB

* Machine specifications are subject to change without notice.

The CVC 1206 Capper is a very flexible machine designed to apply and tighten screw-on caps onto containers at rates of up to 150 bottles per minute. The CVC 1206 is Siemens PLC controlled. The system is designed with two pair of belt tightening belt assemblies. Options include tower lamp, hopper level control, cap inspection (level cap, foil seal, and no cap), reject, and reject verification.

- Built to cGMP Standards
- Stainless Steel Construction
- Quick and Easy Change Over

STANDARD FEATURES

- Siemens PLC Controlled
- Cap Tightening Station with 2 Belt Tightening Systems
- Integrated Cap Hopper Elevator (CVC 1206)
- ISO 9001:2015 Certified

AVAILABLE OPTIONS

- Motorized Sanitary Conveyor (4 1/2" wide belt standard or 6" wide belt available)
- Tower Lamp, Hopper Level Control
- Cap Inspection Package (Level Cap, No Cap, Foil Presence)
- Rejection System, Reject Verification
- Dual-belt Gripping System
- 21 CFR Part 11 License

▼ CVC 1206



▼ CVC 1206H

CVC 1200W
(CAP ELEVATOR SORTER)



* Machine specifications are subject to change without notice.

▼ CVC 2000-TS



▼ CVC 4000



The CVC 2000-TS/ CVC 4000 induction cap sealing system is used to apply a hermetic seal over the mouth of a jar or bottle. These seals can provide evidence of tampering, preserve freshness, prevent pilferage, and provide leakage protection during handling or shipping.

STANDARD FEATURES

- Compact Design, easy for integrated with bottle packaging line to proceed foil sealing for bottles
- 5.7" Color Touch Screen, easy for operation and adjustment (CVC 2000-TS)
- Microprocessor control system to ensure the quality stability
- Allows output to follow conveyor speed
- Output Power: 2.25 KW/ 5.0 KW
- Password Protected Settings available (CVC 2000-TS)
- Event Log - can save 4,000 machine production events (CVC 2000-TS)
- 20 Recipes memory for quick access of product information (CVC 2000-TS)
- Control Panel is available as IP65 (options) for complete protection against wash-down routines in packaging line environments.

AVAILABLE OPTIONS

- Stalled bottle, missing foil, loose cap detection
- Reject device with verification
- Infeed bottle stop gate
- 3- color tower lamp
- Front safety shield
- CE model

CVC 2000-TS Technical Specifications

Productivity	Up to 120 BPM (subject to trial confirmation)
Applicable Size	Cap Dia.: Ø30-110 mm (1 1/4" - 4 1/4")
Power Source	220V, 50/60 HZ, 1 PH
Power Consumption	2,250 VA (10.2 A)
Air Pressure	6 bar (87 psi)
Air Consumption	100 NL/min (3.5 CFM)
Machine Dimensions (L x W x H)	792 x 932 x 1,506 mm (2'-7" x 3'-1" x 4'-11")
Machine Weight	160 kg (353 lbs)
Noise Level	≤ 78 dB

* Machine specifications are subject to change without notice.

CVC 4000 Technical Specifications

Productivity	Up to 200 BPM (subject to trial confirmation)
Applicable Size	Cap Dia.: Ø30-110 mm (1 1/4" - 4 1/4")
Power Source	220 V, 50/60 HZ, 3 PH
Power Consumption	5,100 VA (13.4 A)
Air Pressure	6 bar (87 psi)
Air Consumption	100 NL/min (3.5 CFM)
Machine Dimensions (L x W x H)	821 x 1,111 x 2,188 mm (2'-8" x 3'-8" x 7'-2")
Machine Weight	170 kg (375 lbs)
Noise Level	≤ 78 dB

* Machine specifications are subject to change without notice.

The CVC 1208 In-Line Cap Retorquer is designed to retighten screw-on caps after induction sealing at speeds of up to 200 bottles per minute. The 1208 is Siemens PLC controlled. Options include tower lamp, servo torque metering, reject and reject verification.

STANDARD FEATURES

- Siemens PLC Controlled
- Memory Capacity for 50 Jobs
- Cap Tightening Station with 1 Set of Spindles
- Torque Control System (Servo Motor)
- ISO 9001:2015 Certified

AVAILABLE OPTIONS

- Bottle and Cap Check System
- Foil Check Sensor
- Cap Level Check Sensor
- Bottle Check Sensor
- Rejection System
 - Unqualified Caps (Loose Cap or Improper Capping)
 - Missing Foil Liners
 - Insufficient Capping Torque
 - Fallen Bottles
- Rejection Verification
- Safety Guard
- Separator Wheels (for Bottle)
- Backlog Sensor
- Motorized Sanitary Conveyor, Complete Separator Wheels and Backlog Sensor (4 1/2" wide belt standard or 6" wide belt available)
- Tower Lamp
- 21 CFR Part 11 License

CVC 1208 Technical Specifications

Type	U4
Productivity	Up to 200 BPM (subject to trial confirmation)
Applicable Size	Bottle Dia.: Ø30-110 mm (1 1/4" to 4 1/4") Bottle with Cap Height: 50-220 mm (2" to 8 1/2")
Power Source	220 V, 50/60 HZ, 1 PH
Power Consumption	484 VA (2.2 A)
Air Pressure	6 bar (87 psi)
Air Consumption	28.5 NL/min (1 CFM)
Machine Dimensions (L x W x H)	1,115 x 1,075 x 2,265 mm (approx) (3'-8" x 3'-6" x 7'-5")
Machine Weight	319 kg (703 lbs)
Noise Level	≤ 60 dB

* Machine specifications are subject to change without notice.

▼ CVC 1208



▼ CVC MGS

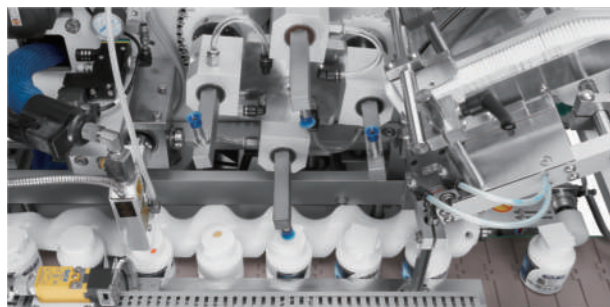

STANDARD FEATURES

- Designed to Meet Relevant cGMP Guidelines, Reducing Cleanup and Inspection
- Easy-to-load Ergonomic Magazine with Outsert Tray Shelf
- The Ability to Incorporate Most Outsert Identification Devices: Bar Code Scanners, Vision and Smart Sensors
- Four-Head Rotary Outsert Feeder
- Stainless Steel Floor Stand
- Screw Adjustable for Bottle Height
- Vacuum Pump System
- Siemens PLC and Touchscreen Operator Interface
- Upstream and Downstream Surge Control
- Missed Outsert Feed Detector
- No Bottle, No Glue and No Outsert Control
- Nordson Model ProBlue 4 Adhesive System with a Single Orifice Gun

AVAILABLE OPTIONS

- Timing Screw or Random Cycle Bottle Control
- Servo Drive
- Bar Code Scanners, Vision Systems and Smart Sensors to Identify and Verify Outserts on the Bottle
- Verified Bottle Reject for Missed or Non-identified Outserts
- Conveyors



CVC MGS Technical Specifications	
Type	U4
Productivity	Up to 200 BPM (subject to trial confirmation)
Applicable Size	Bottle: Dia.: Ø30-110 mm (1 1/4" to 4 1/4") with Cap Height: 63.5-220 mm (2 1/2" to 8 1/2") Manual: Length: 25.4-76.2 mm (1" to 3") Width: 25.4-76.2 mm (1" to 3") Height: 3-14 mm (1/8" to 3/8")
Power Source	220 V, 50/60 HZ, 1 PH
Power Consumption	6,710 VA (30.5 A) (Including hot melt feeder system)
Air Pressure	6 bar (87 psi)
Air Consumption	299 NL/min (10.6 CFM)
Machine Dimensions [L x W x H]	2,829 x 1,047 x 2,094 mm (approx) [9'-3" x 3'-5" x 6'-10"]
Machine Weight	350 kg (772 lbs)
Noise Level	≤ 70 dB

* Machine specifications are subject to change without notice.

CVC 318F are designed for the emerging trend of package reducing in pharmaceutical and nutraceutical industry, external carton is unnecessary for leaflet insertion anymore.

STANDARD FEATURES

- Controlled by Siemens PLC and a Touch-screen panel is provided as the HMI.
- Optional Camera System for outserter optical inspection ensures correctness of Bar Codes printed on leaflets and no leaflets are missing on the bottles.
- Construction fully responds to strict FDA guidelines for bottles and leaflets.
- Optional SIEMENS Control System, available with 21CFR Part 11 Solutions.



CVC 318F Technical Specifications	
Type	U4
Productivity	Up to 120 BPM (subject to trial confirmation) (base on Ø30-78 bottle: screw pitch=80)
Applicable Size	Bottle: Dia.: Ø30-110 mm (1 1/4" to 4 1/4") with Cap Height: 50-220 mm (2" to 8 1/2") Manual: Length: 25.4-38.1 mm (1" to 1 1/2") Width: 25.4-38.1 mm (1" to 1 1/2") Height: 3-14 mm (1/8" to 9/16")
Power Source	220 V, 50/60 HZ, 1 PH
Power Consumption	5,000 VA (22.8 A) (Including hot melt feeder system)
Air Pressure	6 bar (87 psi)
Air Consumption	233 NL/min (8.2 CFM)
Machine Dimensions [L x W x H]	1,421 x 1,200 x 1,935 mm (approx) [4'-8" x 3'-11" x 6'-4"]
Machine Weight	191 kg (421 lbs)
Noise Level	≤ 70 dB

* Machine specifications are subject to change without notice.

▼ CVC 318F



▼ CVC 402



CVC Front and Back Labeler, CVC 402 and CVC Front and Back Labeler with Wrap Station CVC 432 are a dual-purpose machine designed to automatically apply pressure sensitive labels onto square or rectangular containers, and wrapping labels onto round containers. (CVC 432). CVC 402/ CVC 432 using the advanced system (SelfSet™), through this system users can effortlessly set up the diverse parameters like the speed of the motor, label length, labeling speed.

It can also be ordered with an optional assembly for applying a label to 3, 4, or 5 panels of a square or rectangular container. SelfSet™ inspecting all the parameters. Moreover, CVC402/ CVC 432 will record every data and able to output. CVC 402/ CVC 432 can satisfy all your requirements. Multiple applications but 1 Machine!

STANDARD FEATURES (for CVC 402/ 432/ 302/ 302CE)

- SelfSet™ Auto Adjusting Control System
- Servo Motor Driven Head Labeling
- Touch Screen HMI
- Label Head with up to ± 1 mm (1/32") Accuracy (*Bottle/ Containers Dependent)
- Label Sensor for Paper or Opaque Labels
- Product Sensor with Opaque and Clear Bottle Mode
- Separator Wheel for Controlled Spacing
- Stainless Steel Frame on Lockable Casters

CVC 402/ CVC 432 Technical Specifications

Type	U4
Productivity	Up to 210 BPM (CVC 402) Up to 260 BPM (CVC 432) (base on 60 x 120mm square bottle) Up to 230 BPM (CVC 432) (base on 60 ml round bottle) (subject to trial confirmation)
Applicable Size	Label Length: 15-250 mm (5/8" to 10") Label Width: (dependent on label head type) A: 15-80 mm (1/2" to 3") B: 15-120 mm (1/2" to 4 3/8") C: 15-150 mm (1/2" to 6") D: 15-180 mm (1/2" to 7") E: 15-220 mm (1/2" to 8 3/4") F: 15-265 mm (1/2" to 11 1/2") Square Bottle: Length/ Width: 30-110 mm (1 1/4" to 4 1/4") Height: 75-320 mm (2 3/4" to 12 5/8") Flat Bottle: (CVC 432) Length: 30-200 mm (1 1/4" to 7 3/4") Width: 30-110 mm (1 1/4" to 4 1/4") Flat Bottle Height: 75-320 mm (2 3/4" to 12 5/8") Round Bottle: (CVC 432) Height: 50-220 mm (2" to 8 3/4") Dia.: Ø30-110 mm (1 1/4" to 4 1/4")
Power Source	110/220 V, 50/60 HZ, 1 PH
Power Consumption	950 VA (110V: 8.6 A, 220V: 4.3 A)
Air Pressure	6 bar (87 psi)
Air Consumption	78.5 NL/min (2.8 CFM) (for optional reject and Lot/Date printer)
Machine Dimensions [L x W x H]	2,615 x 1,490 x 2,260 mm (8'-7" x 4'-11" x 7'-5")
Machine Weight	400 kg (881 lbs)
Noise Level	≤ 75 dB

* Machine specifications are subject to change without notice.

The CVC 302 High Speed Wrap Labeler is built to automatically apply pressure sensitive labels onto round containers at up to 150 bottles per minute. The 302 is servo motor controlled, comes standard with a touch screen HMI, and can be ordered with various inspection options including bar code verification, vision, and missing label detection.

AVAILABLE OPTIONS (for CVC 402/ 432/ 302/ 302CE)

- C70 Hot Stamp (Lot/Date Coding)
- Missing Hot Stamp Imprint Check
- Integrated Thermal Printer (Lot/Date, Bar Code and Graphics)
- Dataflex or Similar Lot/Date Code Printer
- Clear, Metallic or Color Label Sensor
- End to end Transfer Plates
- Infeed and outfeed Conveyor Extensions
- Adjustable Tilt for Tapered Bottles
- Product Infeed Tray with Stainless Steel Insert and Paddle for easy Product Loading onto a Rotary Turntable
- Feed Screw
- Custom made Wrap Station
- Camera Detection (OCV System)
- Missing Label Detection System (UV)
- Rejection System
- Rejection Verification Check
- 3-Color Tower Stack Light
- 21CFR Part 11 Compliance
- OPC UA for Data Collection

CVC 302/ CVC 302CE Technical Specifications

Type	U4
Productivity	Up to 150 BPM (subject to trial confirmation) Up to 250 BPM (Tiny Bottle or Feed Screw)
Applicable Size	Label Length: 15-250 mm (1/2" to 9 3/4") Label Width: (dependent on label head type) A: 15-80 mm (1/2" to 3") (only CVC 302) B: 15-120 mm (1/2" to 4 3/8") C: 15-150 mm (1/2" to 6") D: 15-180 mm (1/2" to 7") E: 15-220 mm (1/2" to 8 3/4") Bottle Dia.: Ø30-110 mm (1 1/4" to 4 1/4") (dependent on conveyor width) Bottle Height: 50-320 mm (2" to 12 1/2")
Power Source	220 V, 50/60 HZ, 1 PH
Power Consumption	880 VA (4 A)
Air Pressure	6 bar (87 psi)
Air Consumption	78.5 NL/min (2.8 CFM) (for optional reject and Lot/Date printer)
Machine Dimensions [L x W x H]	CVC 302: 3,080 x 1,295 x 2,125 mm (10'-1" x 4'-3" x 7") CVC 302CE: 3,080 x 1,385 x 2,375 mm (10'-1" x 4'-7" x 7'-10")
Machine Weight	CVC 302: 370 kg (816 lbs) CVC 302CE: 536 kg (1,182 lbs)
Noise Level	≤ 75 dB

* Machine specifications are subject to change without notice.

▼ CVC 302



▼ CVC 302 CE



▼ CVC 432

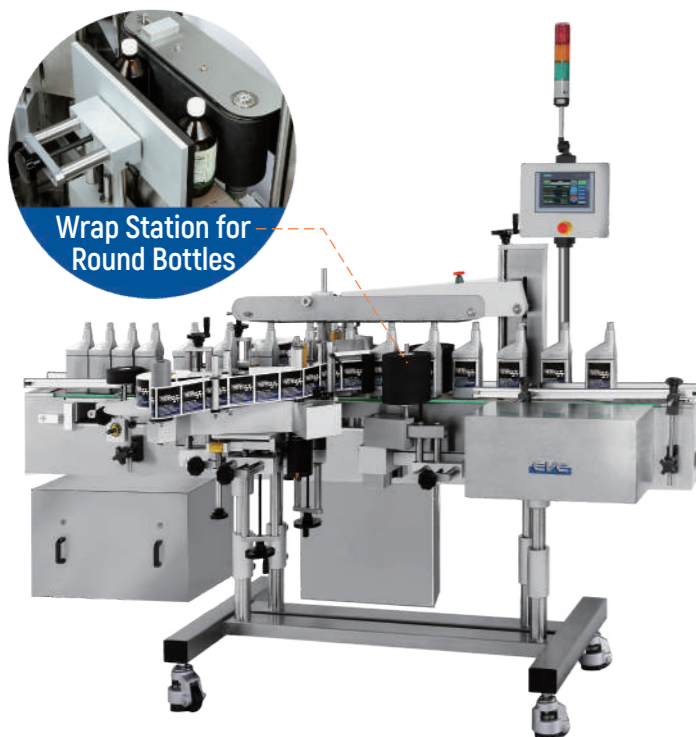

▼ CVC C1200



Companies that process and package products use checkweighers to make sure they do not sell too much or too little of the product in question to the end-user.

Checkweighers are also used for statistical analysis in the companies, strict quality control and cost reduction purposes.

The product is weighed while it is on the production line. Weight zones are defined for all products in advance and items that are not within their weight zone are rejected during production.

Checkweighers can carry out weighings while the conveyor moves either continuously or intermittently. The conveyor is not stopped when the product is being weighed in continuous mode. In intermittent mode, the product is stopped briefly on the checkweigher and weighed.



▼ CVC MD1430SS



The CVC MD1430SS utilise a low power, high frequency, magnetic field coil system that has the ability to sense minute disturbances created by metal particles. A metal particle passing through the aperture of the detector creates changes in the magnetic field inside the detector.

STANDARD FEATURES

- User Interface: The metal detector incorporates a large 5.7" colour QVGA display with a touch screen user interface and Windows-style software using icons.
- Ultimate Detection Capability: The metal detector utilises Digital Signal Processor (DSP) technology and advanced signal processing techniques in order to optimise detection sensitivity to all types of metal contamination.
- Product Numbers: Up to 100 different products can be set up and stored individually in the memory of the metal detector.
- Automatic Setup: This feature allows the metal detector's operating frequency, phase and sensitivity controls to be set up automatically to allow reliable inspection of the product, at an optimized performance level.
- Reject Confirmation: The reject confirmation feature verifies the operation of the reject device. It works in parallel with the metal detector reject timer to ensure that a metal detection event successfully operates the reject device at the correct time or that the contaminated product is successfully rejected.

The CVC 1661/ CVC 1651 Shrink Bundler & Shrink Tunnel is a user friendly, compact machine designed to shrink bundle small and medium sized products. Machine options include multiple in-feed configurations and a single or double discharge depending upon rate requirements. The 1661/ CVC 1651 is an ideal machine for the Nutraceutical, Pharmaceutical, Food and Beverage Markets.

- Built to cGMP Standards
- Painted Steel or Stainless Steel Construction
- Economical Value
- Quick & Easy Change Over

STANDARD FEATURES

- Painted Steel or Stainless Steel Construction
- Single, Indexing Product Loader and 2-Sided Sealer
- Integrated Heat Shrink Tunnel
- Quick Product Size Changeover
- Machine on Casters for Ease of Movement
- Light, Compact Design
- Rate: Dependent Upon Bottle Matrix

AVAILABLE OPTIONS

- Product Change Part
- Variable Speed Drive for In-feed Conveyor
- 1.0M Outlet Gravity Roller Conveyor, SUS 304 Stainless



CVC 1661 Technical Specifications

Productivity	Up to 8-10 Packs/ min (subject to trial confirmation)
Single-Bundle Loader	Max Width: 410 mm (16")
	Max Length: 355 mm (14")
	Max Height: 222 mm (8 3/4")
Two-Bundle Loader	Max Width: 292 mm (11 1/2")
	Max Length: 247 mm (9 3/4")
	Max Height: 222 mm (8 3/4")
Film Roll Specs Single-Bundle Loader	Max Roll Width: 520 mm (20 1/2")
Film Roll Specs Two-Bundle Loader	Max Roll Width: 279 mm (11") Max Roll Outer Dia.: 292 mm (11 1/2")
Power Source	220 V, 50/60 HZ, 3 PH
Power Consumption	1,000 VA (2.7 A)
Air Pressure	6 bar (87 psi)
Air Consumption	320 NL/min (0.6 CFM)
Machine Dimensions [L x W x H]	4,210 x 2,480 x 1,780 mm (approx) (13'-10" x 8'-2" x 5'-10")
Machine Weight	450 kg (992 lbs)

* Machine specifications are subject to change without notice.

▼ CVC 1661

CVC 1651 (HEAT SHRINK TUNNEL)

