



CVC TECHNOLOGIES, INC.



www.cvctechnologies.com

U.S. Headquarters: Fontana, California



● CVC Technologies, Inc.
10861 Business Drive, Fontana, CA 92337, USA
Phone: +1 (909) 355-0311
Fax: +1 (909) 355-0411
<http://www.cvcusa.com>
E-mail: sales@cvcusa.com

● CVC USA East Coast Office
1855 New Highway, Suite C, Farmingdale NY 11735
Phone: +1 (909) 355-0311
Fax: +1 (909) 355-0411
E-mail: sales@cvcusa.com

Asia Headquarters: Taiwan Manufacturing Center



● CVC Technologies, Inc. (Taiwan)
Asia Pacific Headquarters
No.190, Gongye 9th Rd., Dali Dist., Taichung City 412, Taiwan
Phone: +886 (4) 2496-3666
Fax: +886 (4) 3705-6555
E-mail: sales@cvcttechnologies.com

● CVC Technologies, Inc. (India)
601/602, Manmandir Suraksha, Building No.3, Nahur Village Road,
Mulund (W), Mumbai - 400 080
Phone: +91 (22) 2562-1242, +91 (22) 2562-1243
Fax: +91 (22) 2562-1244
E-mail: sales@cvcttechnologies.com

● CVC Technologies, Inc. (China)
No.77, Kangzhuang Road, Kunshan, China
Postal Code: 215314
Phone: +86 (512) 8363-6368
Fax: +86 (512) 8363-6638
E-mail: sales@cvcttechnologies.com



focusing on
WHAT MATTERS THE MOST
to our customers



CREATING TOMORROW'S LABELER TODAY

INNOVATIVE SIMPLE SMART SOLUTIONS

FOR COMPLEX PACKAGING REQUIREMENTS

**OUCH !
LABELER SET-UP TIME IS KILLING ME.
GIVE ME SELFSET™ !**



Enjoy peace of mind with a CVC **SelfSet™** labeler. Simply place a container on the conveyor and with just a press of a button, all speed adjustments are instantly calculated and synchronized for the start of your next production run. Your automatic labeler setup has never been so easy!

SelfSet™ labeling machines are exclusively designed and engineered by CVC with highly advanced labeling technologies. CVC engineers created the **SelfSet™** labeling concept to provide you with the very best in labeling performance. CVC's ever increasing growth is a direct result of new product development and technological superiority.

CVC **SelfSet™** provides advanced microprocessor capability that far exceeds all other labeling systems.

CVC **SelfSet™** can also equip with many other advanced features.



FOUR KEY POINTS FOR PERFECT LABELING !!

THE FOUR MOST COMMON LABELER PROBLEMS ARE:

- (1) Incorrect operator set-up
- (2) Unreliable electronic controls
- (3) Label wrinkles
- (4) Poor labeling accuracy.

CVC **SelfSet™** labelers provide the following unique features to eliminate these problems.

I CVC **SelfSet™** - No operator adjustment is required for the product sensor or label sensor.

The CVC **SelfSet™** labeling system provides the optimum sensing position for every label length and container length or diameter, eliminating the need for moving the product sensor or label sensor. Other labeling machines consume much time and require expert adjustment when changing labels or containers.



II CVC **SelfSet™** control system synchronizes speed for all moving parts.

When the first product passes the product sensor, the CVC **SelfSet™** microprocessor will scan and identify the product length or diameter and label length. The labeling dispensing point, dispensing speed, and label extension position are all automatically set and synchronized. This entire process takes only about three seconds and makes product or label change over time quick and easy. With only one pass of any container the CVC **SelfSet™** system will quickly read the bottle and set up speeds for all motors. Product labeling speed may then be increased or decreased at a single touch.



III Automatic adjustment of label sensor prevents wrinkles and misfeeds.

The **SelfSet™** labeling system automatically calculates the optimum sensitivity and label placement without moving the label sensor! No more short feeds, wrinkles or multiple label feeds because of improper sensitivity settings! Save up to 50 jobs into memory and recall them at the push of a button. If it is a new job, just run **SelfSet™**, then save it!



IV CVC labelers provide superior label placement accuracy.

CVC uses only stepper or servo labeler motors, calibrated settings and special product handling features to achieve label placement accuracy of up to ± 1 mm ($1/32$ ").



World exclusive SelfSet™ - the best assistant to machine operation

- CVC high response frequency encoders with microprocessor (or PLC) control provide wrinkle-free labeling.
- The T.S.T. (Touch Screen Terminal) shows all automatic settings including product output and label remaining.
- **SelfSet™** automatically generates initial settings of motor speed, label stop position, and bottle application "timing" by utilizing encoding technology. Operator can increase or decrease labeling speed by pressing one button. All motors are synchronized to provide labeling accuracy constantly.
- **SelfSet™** also enables the display of "Product Output" and "Labels Remaining".
- "Low Label Alarm" :
 (1) Short sound alarms when the quantity of labels remained falls below 500 pieces.
 (2) Long sound alarms when the quantity of labels remained falls below 200 pieces.
- Machine is made of stainless steel frame on lockable casters.
- Modular design is utilized for interchangeability of components.
- CVC R&D and manufacturing process are ISO 9001:2015 certified.
- Labeling Accuracy is up to ± 1 mm (1/32").
- Servo motor driver labeler is able to install high speed hot stamper (C70); outputs up to 300 impressions per minute.

CVC.... Creating Tomorrow's Machinery Today!

FEATURES:

- Operator places a product on the conveyor and pushes a button on the control panel. The CVC SelfSet™ Labeler immediately sets the speed for all moving parts.
- No repositioning of label sensor is needed for different label lengths.
- SelfSet™ measures the label and adjusts the label sensor automatically.
- Changes in Labeling Speed are made by pressing the (+) or (-) button. No other adjustments are needed.
- No repositioning of the product sensor is necessary when changing bottle size.
- Up to 50 job set-ups can be stored in memory for easy recall.
- Alarm sounds when only 500 labels are left on the label roll.
- SelfSet™ stops labeler and displays an error message when labels run out.
- SelfSet™ stops labeler and displays message when a label is missing off the roll.
- Alarm sounds when hot stamp ribbon roll is depleted.
- ISO 9001: 2015 certified for strict quality control.
- Labeling Machinery and a complete spare parts inventory are available from Southern California for prompt delivery.

High Output: Faster Production

CVC SelfSet™ Labelers increase productivity and reduce labor costs.



The CVC 220 Top & Bottom Labeler is built to automatically pressure sensitive labels onto two sides of flat and indented containers. The 220 comes standard with a 6" wide belt conveyor and is ideal for contract packagers and manufacturers serving the nutraceutical, food, cosmetic, personal care, and consumer electronic markets.

All CVC labelers include our SelfSet™ software which utilizes a high frequency encoder for extremely easy setup and wrinkle free labeling at the touch of a button.

STANDARD FEATURES

- SelfSet™ Auto Adjusting Control System
- Stepper Motor Driven Head Labeling
- Touch Screen HMI
- Label Head with up to ± 1 mm (1/32") Accuracy (*Bottles/ Containers Dependent)
- Label Sensor for Paper or Opaque Labels
- Stainless Steel Frame on Lockable Casters
- Stainless Steel Flatbed Conveyor, 6" Wide Endless Green Belt

AVAILABLE OPTIONS

- C60 Hot Stamp (Lot/Date Coding)
- Missing Hot Stamp Imprint Check
- Integrated Thermal Printer (Lot/Date, Bar Code and Graphics)
- Dataflex or Similar Lot/Date Code Printer
- Clear, Metallic or Color Label Sensor
- End to end Transfer Plates
- Infeed and Outfeed Conveyor Extensions
- Separator Wheel for Controlled Spacing

CVC 220 Technical Specifications

Type	U1
Productivity	Up to 150 PPM (subject to trial confirmation) Dispense Speed: 16 M/min (52 ft/min)
Applicable Size	Label Length: 15-250 mm (1/2" to 10") Label Width: (dependent on label head type) A: 15-80 mm (1/2" to 3") B: 15-120 mm (1/2" to 4 3/4") C: 15-150 mm (1/2" to 6") Product Length: 30-260 mm (2" to 10 1/4") Product Width: 25-150 mm (1" to 6") Product Height: 15-150 mm (1/2" to 6")
Power Source	110/220 V, 50/60 HZ, 1 PH
Power Consumption	485 VA (110V: 4.4 A, 220V: 2.2 A)
Air Pressure	6 bar (87 psi)
Air Consumption	50 NL/min (1.8 CFM) (for optional Lot/Date printer)
Machine Dimensions [L x W x H]	1,450 x 900 x 1,540-1,675 mm (4'-9" x 2'-11" x 5'-1"-5'-6")
Machine Weight	175 kg (386 lbs)
Noise Level	≤ 75 dB

* Machine specifications are subject to change without notice.

▼ CVC 220



▼ MACHINE WORKING FLOW

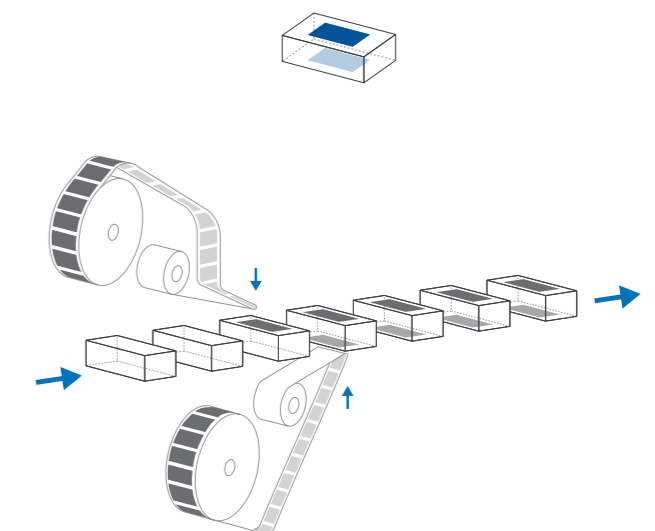

▼ CVC 200



▼ MACHINE WORKING FLOW

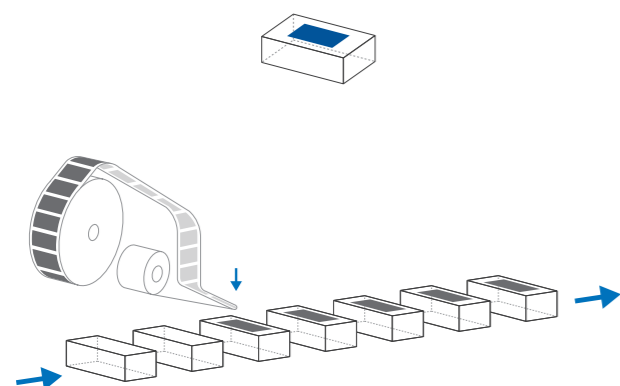

The CVC 200 Ser. Top Labeler is built to automatically apply pressure sensitive labels onto the top or side of flat and indented containers. The CVC 200 Ser. comes standard with a 6" wide belt conveyor and is ideal for contract packagers and manufacturers serving the nutraceutical, food, cosmetic, personal care, and consumer electronic markets.

All CVC labelers include our SelfSet™ software which utilizes a high frequency encoder for extremely easy setup and wrinkle free labeling at the touch of a button.

STANDARD FEATURES

- SelfSet™ Auto Adjusting Control System
- Stepper Motor (or Servo Motor) Driven Head Labeling
- Touch Screen HMI
- Label Head with up to ± 1 mm (1/32") Accuracy (*Bottles/ Containers Dependent)
- Label Sensor for Paper or Opaque Labels
- Stainless Steel Frame on Lockable Casters
- Stainless Steel Flatbed Conveyor, 6" Wide Endless Green Belt

CVC 200 Technical Specifications	
Type	U1
Productivity	Up to 200 PPM (subject to trial confirmation) Dispense Speed: 24 M/min (78 ft/min)
Applicable Size	Label: Length: 15-250 mm (1/2" to 10") Width: (dependent on label head type) A: 15-80 mm (1/2" to 3") B: 15-120 mm (1/2" to 4 3/4") C: 15-150 mm (1/2" to 6") Product: Length: 30-260 mm (1 1/4" to 10 1/4") Width: 25-150 mm (1" to 6") Height: 15-150 mm (1/2" to 6")
Power Source	110/220 V, 50/60 HZ, 1 PH
Power Consumption	350 VA (110V: 3.2 A, 220V: 1.6 A)
Air Pressure	6 bar (87 psi)
Air Consumption	50 NL/min (1.8 CFM) (for optional Lot/Date printer)
Machine Dimensions (L x W x H)	1,320 x 640 x 1485- 1,620 mm (4'-4" x 2'-1" x 4'-10"-5'-4")
Machine Weight	130kg (287 lbs)
Noise Level	≤ 75 dB

* Machine specifications are subject to change without notice.

AVAILABLE OPTIONS

- C60/ C70 Hot Stamp (Lot/Date Coding)
- Missing Hot Stamp Imprint Check
- Integrated Thermal Printer (Lot/Date, Bar Code and Graphics)
- Dataflex or Similar Lot/date Code Printer
- Clear, Metallic or Color Label Sensor
- End to end Transfer Plates
- Infeed and outfeed Conveyor Extensions
- Separator Wheel for Controlled Spacing

ADDITIONAL OPTIONS AVAILABLE with CVC 202:

- Camera Detection (OCV System)
- Missing Label Detection System (UV)
- Rejection System
- Rejection Verification Check
- 3-Color Tower Stack Light
- 21CFR Part 11 License
- OPC UA for Data Collection

CVC 202 Technical Specifications	
Type	U4
Productivity	Up to 200 PPM (subject to trial confirmation) Dispense Speed: 35 M/min (114 ft/min)
Applicable Size	Label: Length: 15-250 mm (1/2" to 10") Width: (dependent on label head type) A: 15-80 mm (1/2" to 3") B: 15-120 mm (1/2" to 4 3/4") C: 15-150 mm (1/2" to 6") D: 15-180 mm (1/2" to 7") Product: Length: 30-260 mm (1 1/4" to 10 1/4") Width: 25-150 mm (1" to 6") Height: 15-150 mm (1/2" to 6")
Power Source	220 V, 50/60 HZ, 1 PH
Power Consumption	880 VA (4 A)
Air Pressure	6 bar (87 psi)
Air Consumption	50 NL/min (1.8 CFM) (for optional Lot/Date printer)
Machine Dimensions (L x W x H)	1,435 x 880 x 1,655 mm (4'-9" x 2'-11" x 5'-5")
Machine Weight	130 kg (287 lbs)
Noise Level	≤ 75 dB

* Machine specifications are subject to change without notice.

▼ CVC 202



▼ CVC 230



▼ MACHINE WORKING FLOW

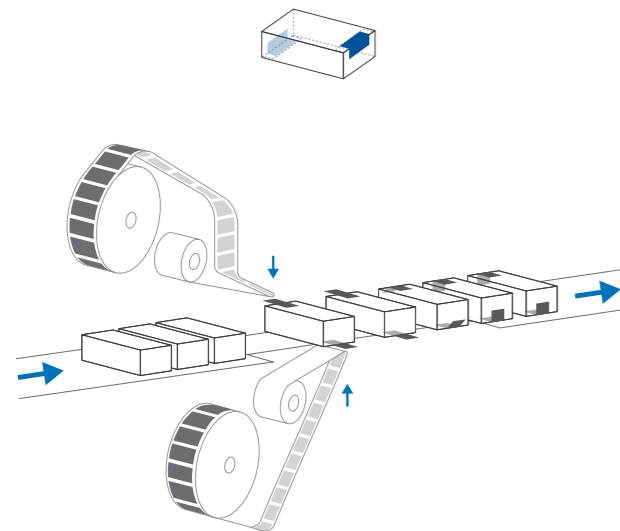

The Model CVC 230/ 232 is a Carton Sealing Labeler featuring CVC exclusive SelfSet™ control system provides wrinkle-free labeling for Top product labeling. The Touch Screen Panel display shows all automatic settings.

All CVC labelers include our SelfSet™ software which utilizes a high frequency encoder for extremely easy setup and wrinkle free labeling at the touch of a button.

STANDARD FEATURES

- SelfSet™ Auto Adjusting Control System
- Stepper Motor (or Servo Motor) Driven Head Labeling
- Touch Screen HMI
- Label Head with up to ± 1 mm (1/32") Accuracy (*Bottles/ Containers Dependent)
- Label Sensor for Paper or Opaque Labels
- Stainless Steel Frame on Lockable Casters
- Stainless Steel Flatbed Conveyor, 6" Wide Endless Green Belt

CVC 230 Technical Specifications	
Type	U1A / U1AW
Productivity	Up to 180 PPM (subject to trial confirmation) Dispense Speed: 30 M/min (98 ft/min)
Applicable Size	Label: Length & Width: 16-30 mm (5/8" to 1 1/4") Optional: 10-15 mm (3/8" to 1/2")
	Carton: Length: (dependent on conveyor type) U1A: 75-120 mm (3" to 4 3/4") U1AW: 105-200 mm (4 1/4" to 8") Width: 20-100 mm (3/4" to 4") Height: 10-100 mm (1/2" to 4")
Power Source	110/220 V, 50/60 HZ, 1 PH
Power Consumption	484 VA (110V: 4.4 A, 220V: 2.2 A)
Air Pressure	6 bar (87 psi)
Air Consumption	50 NL/min (1.8 CFM) (for optional Lot/Date printer)
Machine Dimensions (L x W x H)	1,815 x 1,025 x 1,580-1,670 mm (5'-11" x 3'-4" x 5'-2"-5'-6")
Machine Weight	270 kg (595 lbs)
Noise Level	≤ 75 dB

* Machine specifications are subject to change without notice.

AVAILABLE OPTIONS

- C60/ C70 Hot Stamp (Lot/Date Coding)
- Missing Hot Stamp Imprint Check
- Integrated Thermal Printer (Lot/Date, Bar Code and Graphics)
- Dataflex or Similar Lot/Date Code Printer
- Clear, Metallic or Color Label Sensor
- End to end Transfer Plates
- Infeed and outfeed Conveyor Extensions
- Separator Wheel for Controlled Spacing

ADDITIONAL OPTIONS AVAILABLE with CVC 232:

- Camera Detection (OCV System)
- Missing Label Detection System (UV)
- Rejection System
- Rejection Verification Check
- 3-Color Tower Stack Light
- 21CFR Part 11 Compliance
- OPC UA for Data Collection



CVC 232 Technical Specifications	
Type	U4A / U4AW
Productivity	Up to 260 PPM (subject to trial confirmation) Dispense Speed: 35 M/min (114 ft/min)
Applicable Size	Label: Length & Width: 16-30 mm (5/8" to 1 1/4") Optional: 10-15 mm (3/8" to 1/2")
	Carton: Length: (dependent on conveyor type) U4A: 75-120 mm (3" to 4 3/4") U4AW: 105-200 mm (4 1/4" to 8") Width: 20-100 mm (3/4" to 4") Height: 10-100 mm (1/2" to 4")
Power Source	220 V, 50/60 HZ, 1 PH
Power Consumption	950 VA (4.3 A)
Air Pressure	6 bar (87 psi)
Air Consumption	50 NL/min (1 CFM) (for optional reject and Lot/Date printer)
Machine Dimensions (L x W x H)	1,760 x 800 x 2,050 mm (Including lamp tower) (5'-9" x 2'-7" x 6'-9")
Noise Level	≤ 75 dB

* Machine specifications are subject to change without notice.

▼ CVC 232



▼ PACKED PRODUCTS

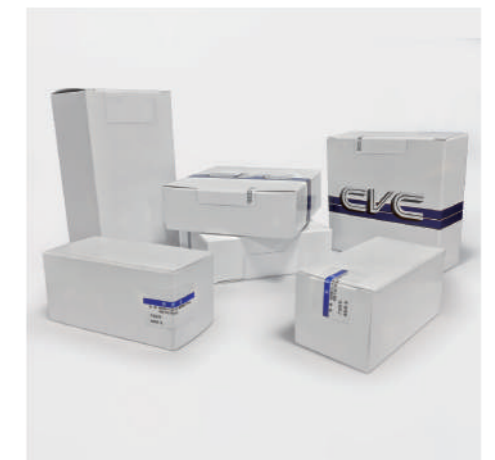

▼ CVC 300



▼ MACHINE WORKING FLOW

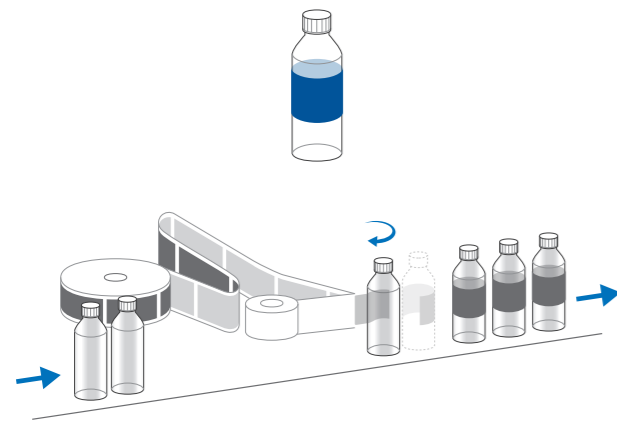

The CVC 300 Ser. Wrap-Around Labeler is built to automatically apply pressure sensitive labels onto round containers. It is an ideal machine for contract packagers and manufacturers serving the nutraceutical, food, cosmetic, personal care, and household product markets.

All CVC labelers include our SelfSet™ software which utilizes a high frequency encoder for extremely easy setup and wrinkle free labeling at the touch of a button.

STANDARD FEATURES

- SelfSet™ Auto Adjusting Control System
- Stepper Motor Driven Head Labeling
- Touch Screen HMI
- Label Head with up to ± 1 mm (1/32") Accuracy (*Bottles/ Containers Dependent)
- Label Sensor for Paper or Opaque Labels
- Product Sensor with Opaque and Clear Bottle Mode
- Variable Speed Separator Wheel
- Stainless Steel Frame on Lockable Casters
- Stainless Steel Flat-bed Conveyor with 4" Wide Table Top Chain (Raised Sanitary Bed) Upgradeable to 6" Wide

AVAILABLE OPTIONS

- C60 Hot Stamp (Lot/Date Coding)
- Missing Hot Stamp Imprint Check
- Integrated Thermal Printer (Lot/Date, Bar Code and Graphics)
- Dataflex or Similar Lot/Date Code Printer
- Clear, Metallic or Color Label Sensor
- End to end Transfer Plates
- Infeed and outfeed Conveyor Extensions
- Adjustable Tilt for Tapered Bottles
- Product Infeed Tray with Stainless Steel Insert and Paddle for easy Product Loading onto a Rotary Turntable
- Feed Screw (*)
- Custom made Wrap Station
- Spindle Wrap Station
- Stainless Steel Raised Bed Sanitary Conveyor (Factory installed only)

* Standard CVC 330 Labeler equips with a Bottle Feed Screw

CVC 300 Technical Specifications

Type	U1
Productivity	Up to 160 BPM (subject to trial confirmation) Labeling Speed: 38 M/min (124 ft/min)
Applicable Size	Label: Length: 15-250 mm (1/2" to 10") Width: (dependent on label head type) A: 15-80 mm (1/2" to 3") B: 15-120 mm (1/2" to 4 3/4") C: 15-150 mm (1/2" to 6") D: 15-180 mm (1/2" to 7") E: 15-220 mm (1/2" to 8 3/4") F: 15-265 mm (1/2" to 11 1/2") Bottle: Dia.: Ø25-102 mm (1" to 4") (dependent on conveyor width) Height: 50-320 mm (2" to 12 1/2")
Power Source	110/220 V, 50/60 HZ, 1 PH
Power Consumption	352 VA (110V: 3.2 A, 220V: 1.6 A)
Air Pressure	6 bar (87 psi)
Air Consumption	50 NL/min (1.8 CFM) (for optional Lot/Date printer)
Machine Dimensions [L x W x H]	2,000 x 1,070 x 1,425 mm (Including conveyor) [6'-7" x 3'-6" x 4'-8"]
Machine Weight	174 kg (384 lbs)
Noise Level	≤ 75 dB

* Machine specifications are subject to change without notice.

CVC 310 Technical Specifications

Type	U1
Productivity	Up to 120 BPM Labeling Speed: 30 M/min (98 ft/min)
Applicable Size	Label Length: 15-450 mm (1/2" to 18") Label Width: (dependent on label head type) A: 15-80 mm (1/2" to 3") B: 15-120 mm (1/2" to 4 3/4") C: 15-150 mm (1/2" to 6") D: 15-180 mm (1/2" to 7") E: 15-220 mm (1/2" to 8 3/4") F: 15-265 mm (1/2" to 11 1/2") Bottle Dia.: Ø30-150 mm (1 1/4" to 6") (dependent on conveyor width) Bottle Height: 50-320 mm (2" to 12 1/2")
Power Source	110/220 V, 50/60 HZ, 1 PH
Power Consumption	725 VA (110V: 6.6 A, 220V: 3.3 A)
Air Pressure	6 bar (87 psi)
Air Consumption	50 NL/min (1.8 CFM) (for optional Lot/Date printer)
Machine Dimensions [L x W x H]	2,000 x 1,140 x 1,425 mm (Including conveyor) [6'-7" x 3'-9" x 4'-8"]
Machine Weight	210 kg (463 lbs)
Noise Level	≤ 75 dB

* Machine specifications are subject to change without notice.

▼ MACHINE WORKING FLOW



CVC 330 Technical Specifications

Type	U1
Productivity	Up to 200 BPM (subject to trial confirmation) Labeling Speed: 38 M/min (124 ft/min)
Applicable Size	Label: Length: 16-254 mm (5/8" to 10") Label Width: (dependent on label head type) A: 15-80 mm (1/2" to 3") B: 15-120 mm (1/2" to 4 3/4") C: 15-150 mm (1/2" to 6") D: 15-180 mm (1/2" to 7") Bottle: Dia.: Ø25-102 mm (1" to 4") (dependent on conveyor width) Height: 50-320 mm (2" to 12 1/2")
Power Source	110/220 V, 50/60 HZ, 1 PH
Power Consumption	396 VA (110V: 3.6 A, 220V: 1.8 A)
Air Pressure	6 bar (87 psi)
Air Consumption	50 NL/min (1.8 CFM) (for optional Lot/Date printer)
Machine Dimensions [L x W x H]	2,000 x 1,460 x 1,430 mm (6'-7" x 4'-9" x 4'-8") (Including conveyor & accumulation rotary table)
Machine Weight	230 kg (507 lbs)
Noise Level	≤ 75 dB

* Machine specifications are subject to change without notice.

▼ CVC 310



▼ CVC 330



▼ CVC 302



▼ MACHINE WORKING FLOW

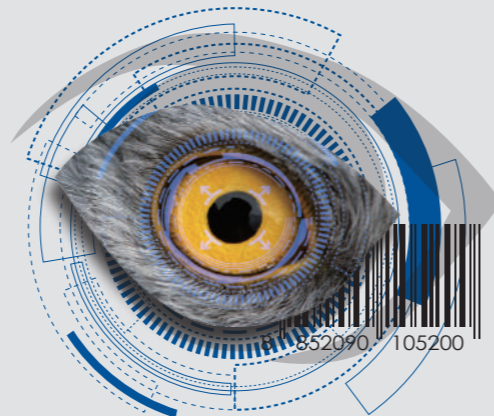
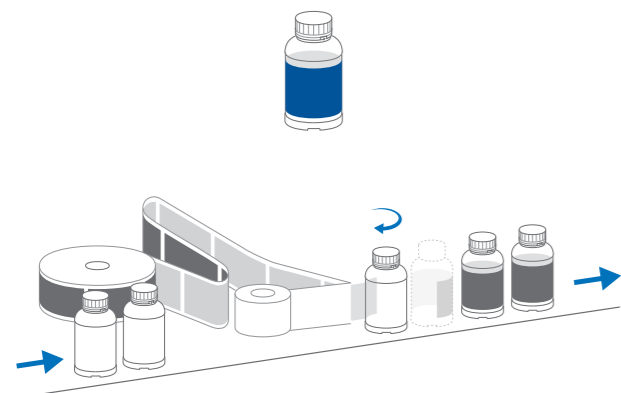

The Hawk™ Labeler is uniquely designed for pharmaceutical as well as other companies that value quality control in packaging

- Stops automatically if the optional bar code scanner can not verify the bar code
- Stops automatically if the label length is incorrect
- Auto rejection system for missing hot stamp code
- Auto rejection system for missing label
- Featuring CVC SelfSet™
- Automatic adjustment of product separation: The CVC 302 automatically regulates distance between each bottle to prevent missing labels caused by bottles crowded
- Servo-driven labeling head brings the remarkable improvement of output labeling speed ranging from 163 to 233 feet per minute
- Meets cGMP requirements, and ISO 9001:2015 standards
- The labeling head is powered by servo motor for increased speed, power and accuracy
- Touch screen control programmed in English, Spanish and Chinese
- The CE model is available upon request

CVC 302/ CVC 302CE Technical Specifications

Type	U4
Productivity	Up to 150 BPM (subject to trial confirmation) Up to 250 BPM (Tiny Bottle and Feed Screw) Labeling Speed: 75 M/min [246 ft/min]
Applicable Size	Label: Length: 15-250 mm [1/2" to 10"] Width: (dependent on label head type) A: 15-80 mm [1/2" to 3"] (only CVC 302) B: 15-120 mm [1/2" to 4 3/4"] C: 15-150 mm [1/2" to 6"] D: 15-180 mm [1/2" to 7"] E: 15-220 mm [1/2" to 8 3/4"] Bottle: Dia.: Ø30-110 mm [1 1/4" to 4 1/4"] (dependent on conveyor width) Height: 50-320 mm [2" to 12 1/2"]
Power Source	220 V, 50/60 HZ, 1 PH
Power Consumption	880 VA (4 A)
Air Pressure	6 bar (87 psi)
Air Consumption	78.5 NL/min [2.8 CFM] (for optional reject and Lot/Date printer)
Machine Dimensions [L x W x H]	CVC 302: 3,080 x 1,295 x 2,125 mm [10'-1" x 4'-3" x 7"] CVC 302CE: 3,080 x 1,385 x 2,375 mm [10'-1" x 4'-7" x 7'-10"]
Machine Weight	CVC 302: 370 kg (816 lbs) CVC 302CE: 536 kg (1,182 lbs)
Noise Level	≤ 75 dB

* Machine specifications are subject to change without notice.

CVC understands that mistakes are costly for manufacturers of pharmaceuticals, nutraceuticals and others. The CVC 302 Hawk™ provides a final check to guard product safety and company reputation.

1. Bar code verification (optional)

If the bar code scanner fails to sense the correct bar code, meaning no bar code or incorrect bar code, the verification system will single for 'error'. The error signal will stop the labeling system and alarm to alert the operator.



2. Label size verification

CVC 302 Hawk™ can verify length of each label to avoid label being misapplied. For instance, when the SelfSet™ identify the standard length is 4", once different sized labels are detected, the labeling system will stop and alarm for attention.



3. Bottle diameter verification

Another common error is the wrongly placed bottle, the optic sensor system CVC 302 Hawk™ equipped scans each bottle to eject unqualified one by identifying the diameter. For instance, when the standard diameter of bottle is 3", once different size is detected, the labeler will stop and alarm for attention.



4. Hot stamp code camera verification system (optional)

This optional aims to avoid hot stamp code missing or false; while irregular labels are detected, the labeling system will stop and alarm to alert. Maximum labeling speed is up to 200 BPM when the option is present.



5. Automatic rejection system (optional)

The labeling system will stop due to irregular situations happening, it needs to be restarted by operators and this will lessen the efficiency. The rejection system is designed to remove all irregular products automatically so the operation will keep carrying on.



6. Label sensor sensitivity adjusts automatically.

The sensibility of label sensor has to be adjusted to meet labels printed by different inks and made of various materials; in the past operators have to try many times to find the best setting. Now you have CVC SelfSet™ the world's wisest system to help you skip complex manual settings. When label changes, CVC SelfSet™ will detect its characteristic and determine the most proper sensibility.



▼ CVC 302 CE



AVAILABLE OPTIONS

- C70 Hot Stamp (Lot/Date Coding)
- Missing Hot Stamp Imprint Check
- Integrated Thermal Printer (Lot/Date, Bar Code and Graphics)
- Dataflex or Similar Lot/Date Code Printer
- Clear, Metallic or Color Label Sensor
- End to end Transfer Plates
- Infeed and outfeed Conveyor Extensions
- Adjustable Tilt for Tapered Bottles
- Product Infeed Tray with Stainless Steel Insert and Paddle for easy Product Loading onto a Rotary Turntable
- Feed Screw
- Custom made Wrap Station
- Camera Detection (OCV System)
- Missing Label Detection System (UV)
- Rejection System
- Rejection Verification Check
- 3-Color Tower Stack Light
- 21CFR Part 11 Compliance
- OPC UA for Data Collection

▼ CVC 350



▼ PACKED PRODUCTS



The CVC 350 Ser. Horizontal Wrap Labeler is built to automatically apply pressure sensitive labels onto round containers that will not convey upright on a conveyor. The 350 comes with a roller chain conveyor and can be purchased with an optional product loader. The 350 Ser. is an ideal machine for contact packagers and manufacturers serving the biotech, nutraceutical, cosmetic, and personal care markets.

STANDARD FEATURES

- SelfSet™ Auto Adjusting Control System
- Stepper Motor (or Servo Motor) Driven Head Labeling
- Touch Screen HMI
- Label Head with up to ± 1 mm ($1/32$ ") Accuracy (*Bottles/ Containers Dependent)
- Label Sensor for Paper or Opaque Labels
- Product Sensor with Opaque and Clear Bottle Mode
- Stainless Steel Frame on Lockable Casters
- Stainless Steel 25 Degree Conveyor with 5- $5/8$ " Wide Roller Chain

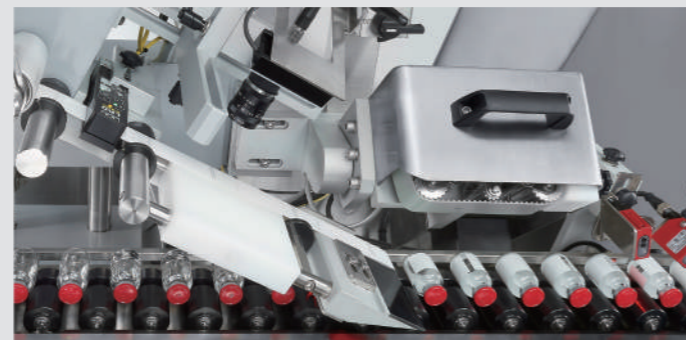

* The tension adjustable wrap belt can tolerate differentials of each ampule and prevents breakage under high speed operation. Flip design enables easy cleaning.

CVC 350 Technical Specifications

Type	U1
Productivity	Up to 250 BPM (subject to trial confirmation) Labeling Speed: 38 M/min (124 ft/min)
Applicable Size	Label: Length: 15-75 mm ($1/2$ " to 3") Width: (dependent on label head type) A: 15-39 mm ($1/2$ " to $1 1/2$ ") B: 15-96 mm ($1/2$ " to $3 3/4$ ") Bottle: Dia.: \emptyset 10-24mm ($3/8$ " to 1") (dependent on conveyor width) Height: 40-70 mm ($1 1/2$ " to $2 3/4$ ")
Power Source	110/220 V, 50/60 HZ, 1 PH
Power Consumption	352 VA (110V: 3.2 A, 220V: 1.6 A)
Air Pressure	6 bar (87 psi)
Air Consumption	50 NL/min (1.8 CFM) (for optional Lot/Date printer)
Machine Dimensions (L x W x H)	1,730 x 800 x 1,560 mm (5'-8" x 2'-7" x 5'-1")
Machine Weight	230 kg (507 lbs)
Noise Level	≤ 75 dB

* Machine specifications are subject to change without notice.

AVAILABLE OPTIONS

- C60/ C70 Hot Stamp (Lot/Date Coding)
- Missing Hot Stamp Imprint Check
- Integrated Thermal Printer (Lot/Date, Bar Code and Graphics)
- Dataflex or Similar Lot/Date Code Printer
- Clear, Metallic or Color Label Sensor
- Product Loader
- Adjustable Tilt for Tapered Bottles
- Custom made Wrap Station
- Automatic Vertical Stand-up Accumulation System

ADDITIONAL OPTIONS AVAILABLE with CVC 232:

- Camera Detection (OCV System)
- Missing Label Detection System (UV)
- Rejection System
- Rejection Verification Check
- 3-Color Tower Stack Light
- 21CFR Part 11 Compliance
- OPC UA for Data Collection

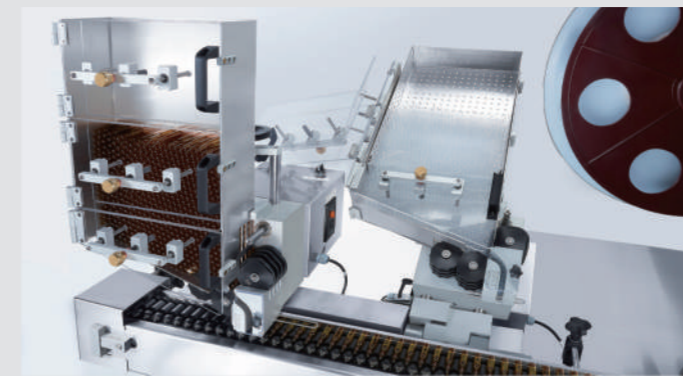

* Ampoule/ Vial loading cassette can be refilled while the machine is running (Option)

CVC 352 Technical Specifications

Type	U4
Productivity	Up to 300 BPM (subject to trial confirmation) Dispense Speed: 70 M/min (229 ft/min)
Applicable Size	Label: Length: 15-75 mm ($1/2$ " to 3") Label Width: (dependent on label head type) A: 15-39 mm ($1/2$ " to $1 1/2$ ") B: 15-96 mm ($1/2$ " to $3 3/4$ ") Bottle: Dia.: \emptyset 10-24 mm ($1/2$ " to 1") (dependent on conveyor width) Height: 40-70 mm ($1 1/2$ " to $2 3/4$ ")
Power Source	220 V, 50/60 HZ, 1 PH
Power Consumption	1,100 VA (5 A)
Air Pressure	6 bar (87 psi)
Air Consumption	78.5 NL/min (2.8 CFM) (for optional reject and Lot/Date printer)
Machine Dimensions (L x W x H)	3,585 x 1,205 x 2,120 mm (Including conveyor) (11'-9" x 3'-11" x 6'-11")
Machine Weight	605 kg (1,334 lbs)
Noise Level	≤ 75 dB

* Machine specifications are subject to change without notice.

▼ CVC 352



* Vertical Loading System (Option)



▼ CVC 400



▼ MACHINE WORKING FLOW

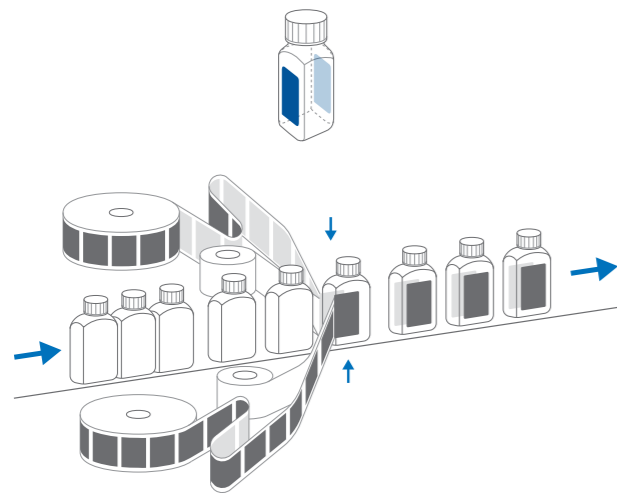

The CVC 400 Ser. Front & Back Labeler is built to automatically apply pressure sensitive labels onto the front and/or back of flat sided, oval, and some round containers. The 400 Ser. can be ordered with one or two labeling heads and has an optional assembly for applying a label to 3, 4, or 5 panels of a square or rectangular container.

STANDARD FEATURES

- SelfSet™ Auto Adjusting Control System
- Stepper Motor (or Servo Motor) Driven Head Labeling
- Touch Screen HMI
- Label Head with up to ± 1 mm (1/32") Accuracy (*Bottle/ Containers Dependent)
- Label Sensor for Paper or Opaque Labels
- Product Sensor with Opaque and Clear Bottle Mode
- Separator Wheel for Controlled Spacing
- Stainless Steel Frame on Lockable Casters

CVC 400 Technical Specifications	
Type	U1
Productivity	Up to 175 BPM (subject to trial confirmation) Labeling Speed: 23 M/min (75 ft/min)
Applicable Size	Label: Length: 15-250 mm (1/2" to 10") Width: (dependent on label head type) A: 15-80 mm (1/2" to 3") B: 15-120 mm (1/2" to 4 3/4") C: 15-150 mm (1/2" to 6") D: 15-180 mm (1/2" to 7") E: 15-220 mm (1/2" to 8 3/4") F: 15-265 mm (1/2" to 11 1/2") Bottle: Length: 30-200 mm (1 1/4" to 7 3/4") Width: 30-110 mm (1 1/4" to 4 1/4") Height: 75-320 mm (3" to 12 1/2")
Power Source	110/220 V, 50/60 HZ, 1 PH
Power Consumption	528 VA (110V: 4.8 A, 220V: 2.4 A)
Air Pressure	6 bar (87 psi)
Air Consumption	50 NL/min (1.8 CFM) (for optional Lot/Date printer)
Machine Dimensions [L x W x H]	2,435 x 1,490 x 1,495 mm (including conveyor) (8' x 4'-11" x 4'-11")
Machine Weight	305 kg (672 lbs)
Noise Level	≤ 75 dB

* Machine specifications are subject to change without notice.

AVAILABLE OPTIONS

- C60/ C70 Hot Stamp (Lot/Date Coding)
- Missing Hot Stamp Imprint Check
- Integrated Thermal Printer (Lot/Date, Bar Code and Graphics)
- Dataflex or Similar Lot/Date Code Printer
- Clear, Metallic or Color Label Sensor
- End to end Transfer Plates
- Infeed and outfeed Conveyor Extensions
- Adjustable Tilt for Tapered Bottles
- Feed Screw
- Stainless Steel Raised Bed Sanitary Conveyor (Factory installed only)
- Push and Press Attachment
- 3-panel, 4-panel or 5-panel Labeling Attachments

ADDITIONAL OPTIONS AVAILABLE with CVC 402:

- Camera Detection (OCV System)
- Missing Label Detection System (UV)
- Rejection System
- Rejection Verification Check
- 3-Color Tower Stack Light
- 21CFR Part 11 Compliance
- OPC UA for Data Collection

CVC 402 Technical Specifications	
Type	U4
Productivity	Up to 210 BPM (subject to trial confirmation) Labeling Speed: 35 M/min (114 ft/min)
Applicable Size	Label: Length: 15-250 mm (1/2" to 10") Label Width: (dependent on label head type) A: 15-80 mm (1/2" to 3") B: 15-120 mm (1/2" to 4 3/4") C: 15-150 mm (1/2" to 6") D: 15-180 mm (1/2" to 7") E: 15-220 mm (1/2" to 8 3/4") F: 15-265 mm (1/2" to 11 1/2") Bottle: Length/Width: 30-110 mm (1 1/4" to 4 1/4") Height: 75-320 mm (3" to 12 1/2")
Power Source	220 V, 50/60 HZ, 1 PH
Power Consumption	950 VA (4.3 A)
Air Pressure	6 bar (87 psi)
Air Consumption	78.5 NL/min (2.8 CFM) (for optional reject and Lot/Date printer)
Noise Level	≤ 75 dB

* Machine specifications are subject to change without notice.

▼ CVC 402



▼ PACKED PRODUCTS



▼ CVC 430



CVC Front and Back Labeler with Wrap Station CVC 430 Ser. are Dual-purpose machine designed to automatically apply pressure sensitive labels onto square or rectangular containers, and wrapping labels onto round containers. CVC 430 Ser. using the advanced system (SelfSet™), through this system users can effortlessly set up the diverse parameters like the speed of the motor, label length, labeling speed.

It can also be ordered with an optional assembly for applying a label to 3, 4, or 5 panels of a square or rectangular container. SelfSet™ inspecting all the parameters. Moreover, CVC 430 Ser. will record every data and able to output. CVC 430 Ser. can satisfy all your requirements. Multiple applications but 1 Machine!

STANDARD FEATURES

- SelfSet™ Auto Adjusting Control System
- Stepper Motor (or Servo Motor) Driven Head Labeling
- Touch Screen HMI
- Label Head with up to ± 1 mm (1/32") Accuracy
- Separator Wheel for Controlled Spacing
- Stainless Steel Frame on Lockable Casters
- Stainless Steel Flatbed Conveyor with Table Top Chain
- Type 304 Stainless Steel Bin, Frame, Enclosure Panels

▼ PACKED PRODUCTS



CVC 430 Technical Specifications	
Type	U1
Productivity	Up to 175 BPM (subject to trial confirmation) Labeling Speed: 23 M/min (75 ft/min)
Applicable Size	Label: Length: 15-250 mm (1/2" to 10") Width: (dependent on label head type) A: 15-80 mm (1/2" to 3") B: 15-120 mm (1/2" to 4 3/4") C: 15-150 mm (1/2" to 6") D: 15-180 mm (1/2" to 7") E: 15-220 mm (1/2" to 8 3/4") F: 15-265 mm (1/2" to 11 1/2") Flat/ Square Bottle: Length: Flat Bottle: 30-110 mm (1 1/4" to 4 1/4") Square Bottle: 30-200 mm (1 1/4" to 8") Width: 30-110 mm (1 1/4" to 4 1/4") Height: 75-320 mm (2 3/4" to 12 1/2") Round Bottle: Height: 50-220 mm (2" to 8 3/4") Dia.: Ø30-110 mm (1 1/4" to 4 1/4")
Power Source	110/220 V, 50/60 HZ, 1 PH
Power Consumption	528 VA (110V: 4.8 A, 220V: 2.4 A)
Air Pressure	6 bar (87 psi)
Air Consumption	50 NL/min (1.8 CFM) (for optional Lot/Date printer)
Machine Dimensions [L x W x H]	2,435 x 1,430 x 1,435 mm (Including conveyor) [8' x 4'-8" x 4'-8"]
Machine Weight	340 kg (750 lbs)
Noise Level	≤ 75 dB

* Machine specifications are subject to change without notice.

AVAILABLE OPTIONS

- C60/ C70 Hot Stamp (Lot/Date Coding)
- Missing Hot Stamp Imprint Check
- Integrated Thermal Printer (Lot/Date, Bar Code and Graphics)
- Dataflex or Similar Lot/Date Code Printer
- Clear, Metallic or Color Label Sensor
- End to end Transfer Plates
- Infeed and outfeed Conveyor Extensions
- Adjustable Tilt for Tapered Bottles
- Feed Screw
- Stainless Steel Raised Bed Sanitary Conveyor (Factory installed only)
- Push and Press Attachment
- 3-panel, 4-panel or 5-panel Labeling Attachments

ADDITIONAL OPTIONS AVAILABLE with CVC 432:

- Camera Detection (OCV System)
- Missing Label Detection System (UV)
- Rejection System
- Rejection Verification Check
- 3-Color Tower Stack Light
- 21CFR Part 11 Compliance
- OPC UA for Data Collection

CVC 432 Technical Specifications	
Type	U4
Productivity	Up to 260 BPM (Square bottle, subject to trial confirmation) Up to 230 BPM (Round bottle, subject to trial confirmation) Labeling Speed: 35 M/min (114 ft/min)
Applicable Size	Label: Length: 15-250mm (1/2" to 10") Width: (dependent on label head type) A: 15-80 mm (1/2" to 3") B: 15-120 mm (1/2" to 4 3/4") C: 15-150 mm (1/2" to 6") D: 15-180 mm (1/2" to 7") E: 15-220 mm (1/2" to 8 3/4") F: 15-265 mm (1/2" to 11 1/2") Flat/ Square Bottle: Length: Flat Bottle: 30-110 mm (1 1/4" to 4 1/4") Square Bottle: 30-200 mm (1 1/4" to 8") Width: 30-100 mm (1 1/4" to 4") Height: 75-320 mm (2 3/4" to 12 1/2") Round Bottle: Height: 50-220 mm (2" to 8 3/4") Dia.: Ø30-110 mm (1 1/4" to 4 1/4")
Power Source	110/220 V, 50/60 HZ, 1 PH
Power Consumption	950 VA (110V: 8.6 A, 220V: 4.3 A)
Air Pressure	6 bar (87 psi)
Air Consumption	78.5 NL/min (2.8 CFM) (for optional reject and Lot/Date printer)
Machine Dimensions [L x W x H]	2,615 x 1,490 x 2,260 mm (8'-7"x 4'-11"x 7'-5") (Including tower lamp & conveyor)
Noise Level	≤ 75 dB

* Machine specifications are subject to change without notice.

▼ CVC 432



Wrap Station for Round Bottles

* Within 10 minutes to change from "front & back" to "wrap" labeling
Simply lift off CVC's post mounted "Quick Mount™" wrap station and place 2 powered sponge rollers onto the same mounts.

